

YAMAHA

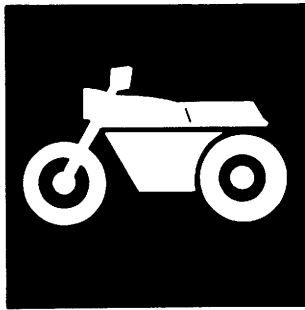

**PARTS
CATALOGUE**

YZ125LC'95 (4PE1) EUROPE

YZ125G (4PE2) U.S.A., CANADA, S. AFRICA

YZ125 (4PE3) JAPAN

YZ125G (4PE4) OCEANIA

154PE-100E1

YAMAHA
GENUINE
Parts & Accessories



A3

FOREWORD

This Parts Catalogue is related to the parts for the model(s) in the below frame. When you are ordering replacement parts, please refer to this Parts Catalogue and quote both part numbers and part names correctly.

YZ125LC*95 (4PE1), YZ125G (4PE2, 4PE4), YZ125 (4PE3)

- Modifications or additions which have been made after issue of the Parts Catalogue will be announced in the Yamaha Parts News.
It is advisable that you make necessary corrections to the Parts Catalogue according to the Yamaha Parts News.

2. Abbreviations

The following abbreviations are used in this Parts Catalogue.

- "UR" Use specified parts number.
- "UN" Use as many as needed.
- "AP" Alternate Parts
- "LM" Local Made (Parts need to be ordered locally)
- "F#" Frame No. (Applicable machine No.)

- Parts, which are to be supplied in an assembly, are listed with a dot (.) in front of the part name as shown below.

EXAMPLE

- CARBURETOR ASSY
- . JET, PILOT
- . NOZZLE, MAIN

4. Number of component for assembly

The numeral appearing to the right of each component part indicates the quantity of parts for each assembly unit.

EXAMPLE

PART NO.	DESCRIPTION	Q'TY	REMARKS
2F5-83310-60	FRONT FLASHER LIGHT ASSY	2	
115-83311-60	. BULB (6V-18W)	1	

5. Applicable colors of graphics are represented in the "REMARKS" as shown below.

PART NO.	DESCRIPTION	Q'TY	REMARKS
2N4-24110-00-X5	FUEL TANK COMP.	1	MAXIM RED
3J1-24240-10	. GRAPHIC, FUEL TANK	1	for MXR

6. Applicable Serial No. and Color Code

4PE1	① Frame Serial No.	4PE-000101	~
	② Engine Serial No.	4PE-000101	~
4PE2	① Frame Serial No.	4PE-004101	~
	② Engine Serial No.	4PE-004101	~
4PE3	① Frame Serial No.	4PE-010101	~
	② Engine Serial No.	4PE	~
4PE4	① Frame Serial No.	4PE-012101	~
	② Engine Serial No.	4PE-012101	~

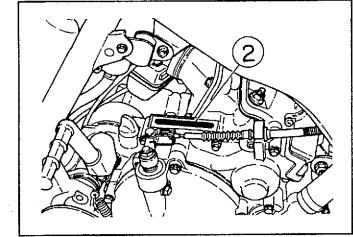
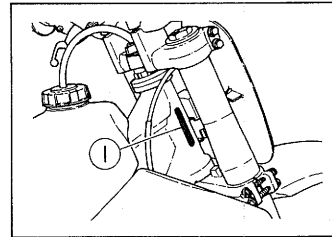

Color Code	Color Name	Abbreviation
0206	PURPLISH WHITE SOLID 1	PWS1

- Note that the illustrations are for reference in finding parts numbers, not to be used for assembling. When assembling, please use the applicable service manual.
- The asterisk (*) before a reference number indicates modification items after the first edition.

CONTENTS

ENGINE

Cylinder Head	B2~B3
Governor	B4
Crankshaft, Piston	B5
Water Pump	B6
Radiator, Hose	B7
Intake	B8
Carburetor	B9~B10
Exhaust	B11
Crankcase	B12
Crankcase Cover 1	B13
Starter	B14
Clutch	B15
Transmission	C2~C3
Shift Cam, Fork	C4
Shift Shaft	C5

CHASSIS

Frame	C6
Fender	C7
Side Cover	C8
Rear Arm	C9~C10
Rear Suspension	C11
Steering	C12
Front Fork	C13~C15
Fuel Tank	D2
Seat	D3
Front Wheel	D4
Front Brake Caliper	D5
Rear Wheel	D6~D7

Rear Brake Caliper	D8
Steering Handle, Cable	D9
Front Master Cylinder	D10
Stand, Footrest	D11
Rear Master Cylinder	D12
Generator	D13
Handle Switch, Lever	D14
Electrical 1	D15

ALTERNATE PARTS

Alternate (Chassis)	E2
---------------------------	----

REPAIR KIT

Repair Kit	E3
------------------	----

INDEX

Numerical Index	M1~M3
-----------------------	-------

FIG. 1 CYLINDER HEAD

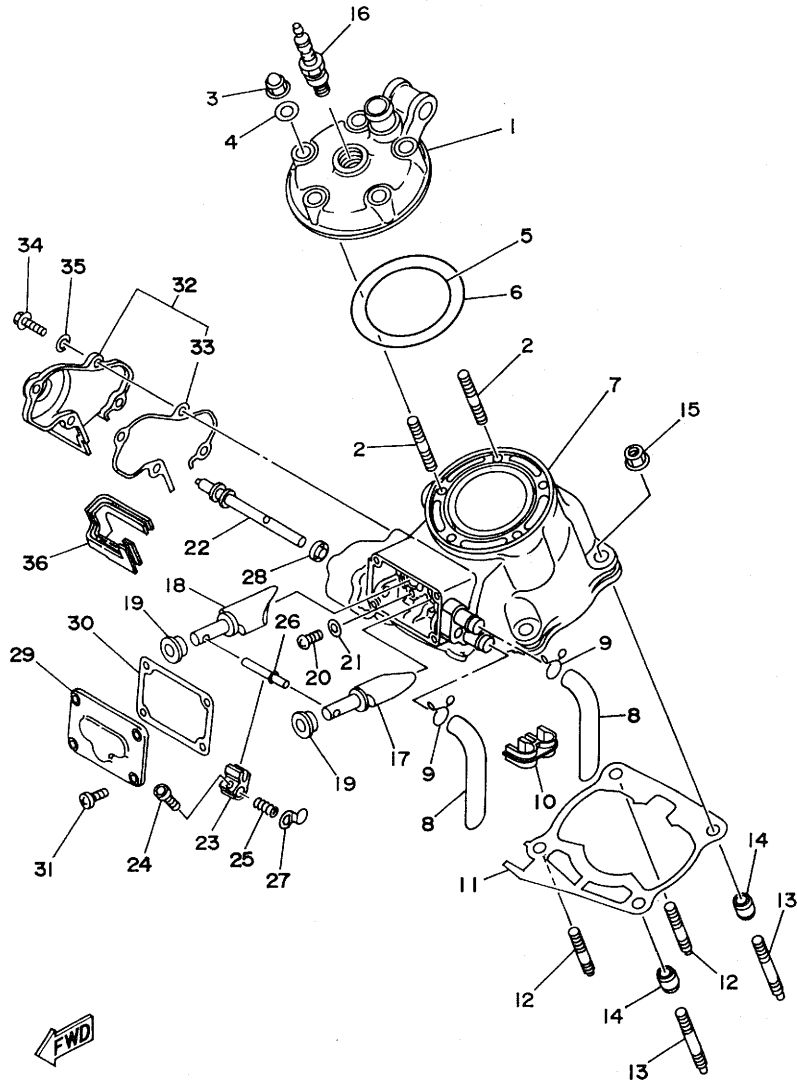

REF. NO.	PART NO.	DESCRIPTION	Q'TY	REMARKS
1	4JY-11111-01	HEAD, CYLINDER 1	1	
2	90116-08394	BOLT, STUD	5	
3	90176-08026	NUT, CROWN	5	
4	90201-08087	WASHER, PLATE	5	
5	93210-63442	O-RING	1	
6	93210-90785	O-RING	1	
7	4PE-11310-00	CYLINDER 1	1	
8	4JY-11166-00	PIPE, BREATHER 1	2	
9	90467-11044	CLIP	2	
10	90464-12224	CLAMP	1	
11	4JY-11351-00	GASKET, CYLINDER	1	
12	90116-08318	BOLT, STUD	2	
13	90116-08388	BOLT, STUD	2	
14	99510-10114	PIN, DOWEL	2	
15	90179-08491	NUT	4	
16	94702-00325	PLUG, SPARK (NGK B9EG)	1	UR
	94703-00325	PLUG, SPARK (NGK B9EG)	1	UR FOR JAPAN
17	4JY-1131A-01	VALVE 1	1	
18	4JY-1132A-01	VALVE 2	1	
19	4JY-1131E-00	HOLDER 1	2	
20	98907-05010	SCREW, BIND	2	
21	90201-057H5	WASHER	2	
22	4JY-1131V-01	SHAFT 1	1	
23	4JY-11832-01	LEVER, LINK	1	
24	91317-04008	BOLT	1	
25	90501-066J1	SPRING, COMPRESSION	1	
26	4JY-11812-00	SHAFT, VALVE	1	
27	4PE-11165-00	PLATE, BREATHER	1	

4PE1100-5010

B2

FIG. 1 CYLINDER HEAD

REF. NO.	PART NO.	DESCRIPTION	Q'TY	REMARKS
28	93104-08040	OIL SEAL	1	
29	4JY-1131M-00	COVER	1	
30	4JY-11354-00	GASKET	1	
31	98907-05014	SCREW, BIND	4	
32	4JY-11991-00	HOUSING 1	1	
33	4JY-11993-00	GASKET	1	
34	97007-05016	BOLT	4	
35	92907-05600	WASHER, PLATE	4	
36	4JY-11995-00	SEAL, HOUSING	1	

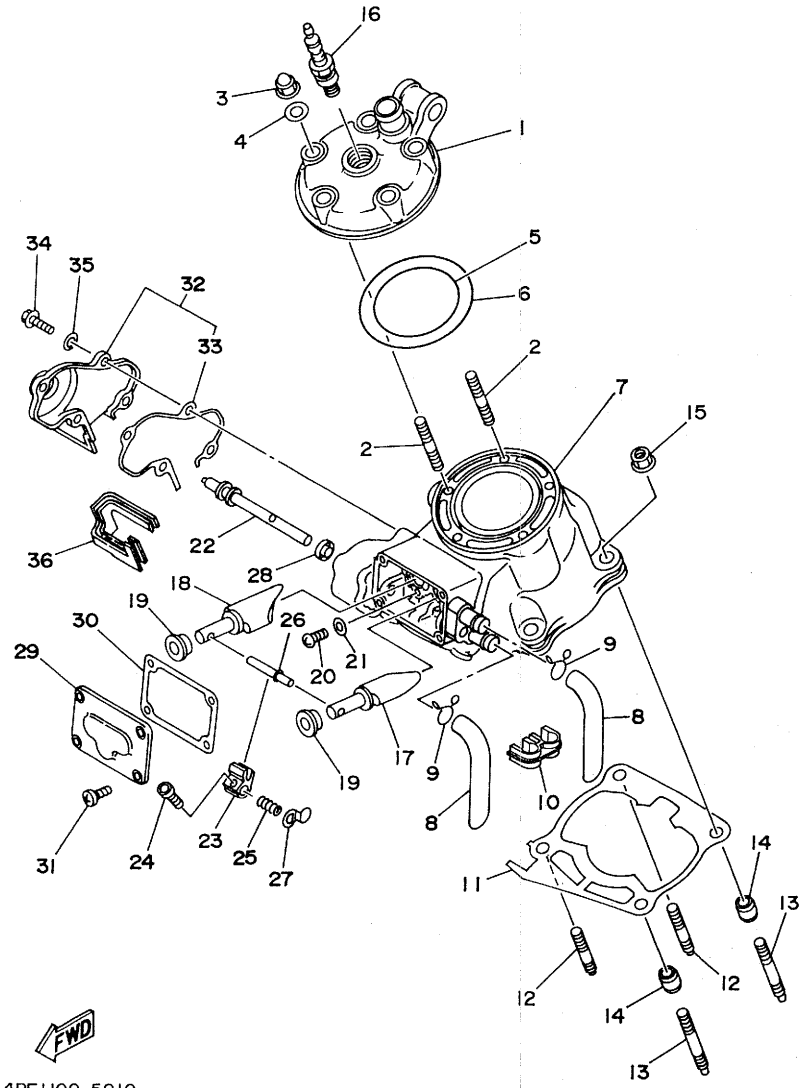

4PE1100-5010

B3

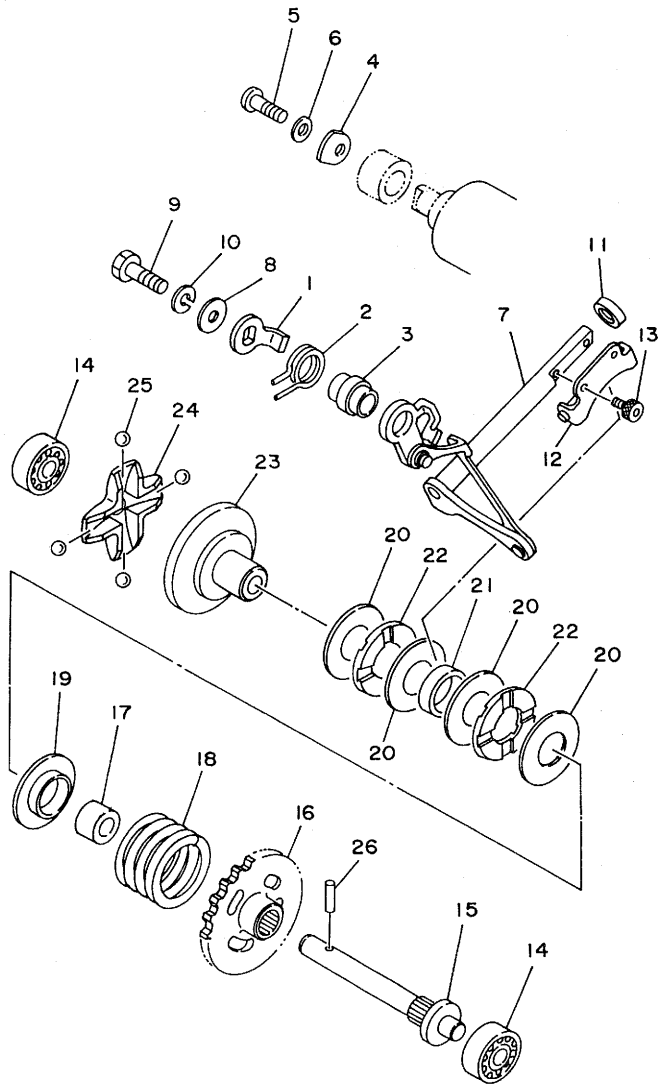

FIG. 2 GOVERNOR

REF. NO.	PART NO.	DESCRIPTION	Q'TY	REMARKS
1	4JY-11931-01	LEVER	1	
2	90508-14783	SPRING, TORSION	1	
3	4JY-11937-00	BOSS, LEVER	1	
4	4JY-11915-00	PLATE, THRUST 1	1	
5	98507-05014	SCREW, PAN HEAD	1	
6	92907-05100	WASHER, SPRING	1	
7	4JY-11990-00	PUSH ROD ASSY	1	
8	90201-057H5	WASHER, PLATE	1	
9	97007-05016	BOLT	1	
10	92907-05100	WASHER, SPRING	1	
11	93104-08040	OIL SEAL	1	
12	3JE-11922-00	FORK, GOVERNOR	1	
13	91317-04006	BOLT	2	
14	93300-60814	BEARING (608M4ML01)	2	NMB
15	5X4-11921-02	SHAFT, GOVERNOR	1	
16	24X-11953-01	GEAR, GOVERNOR	1	
17	90560-08213	SPACER	1	
18	90501-264J6	SPRING, COMPRESSION	1	
19	5X4-11952-00	PLATE	1	
20	90201-154E9	WASHER, PLATE	4	
21	90387-152F2	COLLAR	1	
22	93340-21505	BEARING, THRUST	2	
23	5X5-11912-01	RETAINER, WEIGHT	1	
24	5X5-11911-01	RETAINER	1	
25	93521-64032	BALL	4	
26	93603-14179	PIN, DOWEL	1	



4EP1100-5020

B4

FIG. 3 CRANKSHAFT. PISTON

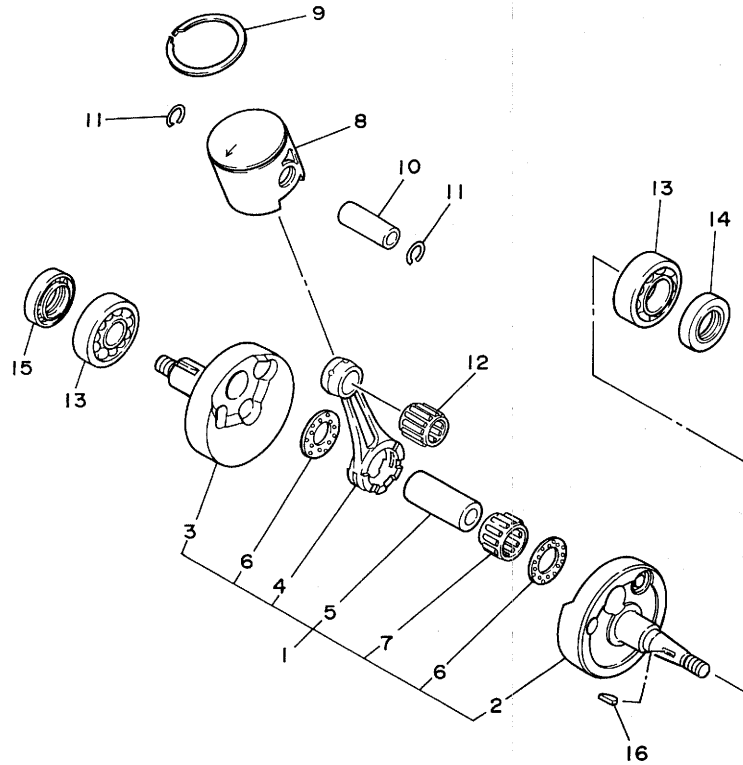

REF. NO.	PART NO.	DESCRIPTION	Q'TY	REMARKS
1	4PE-11400-00	CRANKSHAFT ASSY	1	
2	4JY-11412-00	.CRANK 1	1	
3	4JY-11422-00	.CRANK 2	1	
4	4PE-11651-00	.ROD, CONNECTING	1	
5	3JD-11681-01	.PIN, CRANK 1	1	
6	90209-22257	.WASHER	2	
7	93310-522P7	.BEARING, CYLINDRICAL	1	
8	4JY-11631-00-A0	PISTON (STD)	1	UR RED
	4JY-11631-00-B0	PISTON (STD)	1	UR ORANGE
	4JY-11631-00-C0	PISTON (STD)	1	UR GREEN
	4JY-11631-00-D0	PISTON (STD)	1	UR PURPLE
9	4JY-11611-00	RING, PISTON	1	
10	4PE-11633-00	PIN, PISTON	1	
11	93450-17129	CIRCLIP	2	
12	93310-216L2	BEARING, CYLINDRICAL	1	
13	93306-37204	BEARING (63/22SH2-9TC4)	2	KOYO
14	93102-22363	OIL SEAL	1	
15	93103-32099	OIL SEAL	1	
16	90280-03017	KEY, WOODRUFF	1	



3XJ1100-1030

B5

FIG. 4 WATER PUMP

REF. NO.	PART NO.	DESCRIPTION	Q'TY	REMARKS
1	1LX-12459-00	GEAR, IMPELLER SHAFT	1	
2	1LX-12450-00	IMPELLER SHAFT ASSY	1	
3	99080-07600	CIRCLIP	1	
4	90201-08512	WASHER, PLATE	1	
5	93603-22028	PIN, DOWEL	1	
6	90201-08784	WASHER, PLATE	1	
7	93103-10168	OIL SEAL	1	
8	4JY-12422-00	COVER, HOUSING	1	
9	4JY-12428-00	GASKET, HOUSING COVER 2	1	
10	93604-10011	PIN, DOWEL	2	
11	95027-06065	BOLT, FLANGE	2	
12	95027-06030	BOLT	2	
13	90430-06166	GASKET	1	
14	95027-06010	BOLT	1	

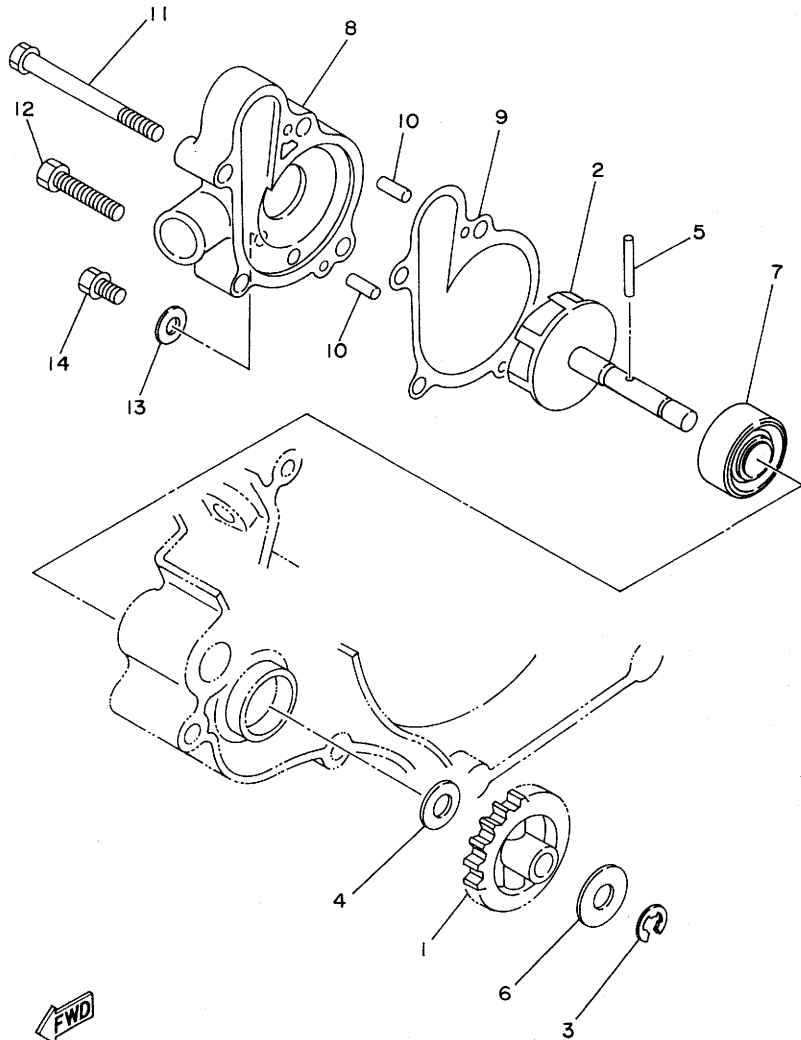

4JY1100-4040

B6

FIG. 5 RADIATOR. HOSE

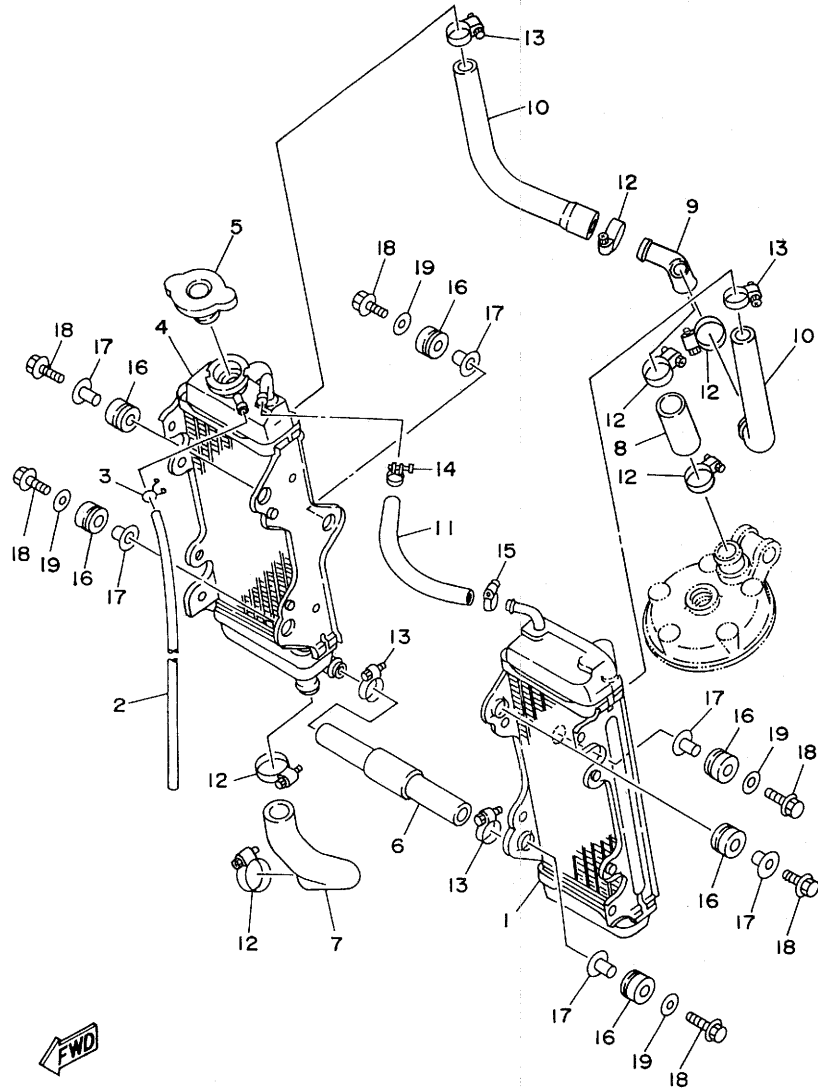

REF. NO.	PART NO.	DESCRIPTION	Q'TY	REMARKS
1	4EW-1240A-01	RADIATOR ASSY	1	
2	91A20-05065	TUBE, FLEXIBLE VINYL	1	
3	90467-09006	CLIP	1	
4	4EX-12461-00	RADIATOR ASSY	1	
5	22W-12462-00	CAP, RADIATOR	1	
6	4EW-12482-01	PIPE 2	1	
7	4JY-12483-00	PIPE 3	1	
8	3AK-12483-00	PIPE 3	1	
9	4EX-12469-00	JOINT 1	1	
10	4EX-12477-01	PIPE 7	2	
11	4DC-1248A-00	PIPE 8	1	
12	90450-28014	HOSE CLAMP ASSY	6	
13	90450-22052	HOSE CLAMP ASSY	4	
14	90450-15041	HOSE CLAMP ASSY	1	
15	90450-17036	HOSE CLAMP ASSY	1	
16	90480-15528	GROMMET	6	
17	90387-0700G	COLLAR	6	
18	95027-06030	BOLT	6	
19	90201-063J2	WASHER, PLATE	4	

4JY1100-4050

B7

FIG. 6 INTAKE

REF. NO.	PART NO.	DESCRIPTION	Q'TY	REMARKS
1	4PE-13610-00	REED VALVE ASSY	1	
2	4PE-13613-00	.REED, VALVE	2	
3	4JY-13616-00	.STOPPER, REED VALVE	2	
4	98507-03008	.SCREW, PAN HEAD	4	
5	92990-03100	.WASHER, SPRING	4	
6	4PE-13565-00	JOINT, CARBURETOR	1	
7	95027-06020	BOLT	4	
8	90450-51070	HOSE CLAMP ASSY	1	
9	90450-70072	HOSE CLAMP ASSY	1	
10	4PE-14453-00	JOINT, AIR CLEANER 1	1	
11	3JD-14459-00	HOLDER, GUIDE	1	
12	3JD-14462-00	SEAL	1	
13	4PE-14411-00	CASE, AIR CLEANER 1	1	
14	3JD-14477-00	PLATE	1	
15	95607-05100	NUT, U	5	
16	4PE-14451-00	ELEMENT, AIR CLEANER	1	
17	3JD-14458-00	GUIDE	1	
18	90209-06096	WASHER	1	
19	90122-06035	BOLT, WING	1	
20	90201-06765	WASHER, PLATE	2	
21	90105-06553	BOLT, WASHER BASED	2	

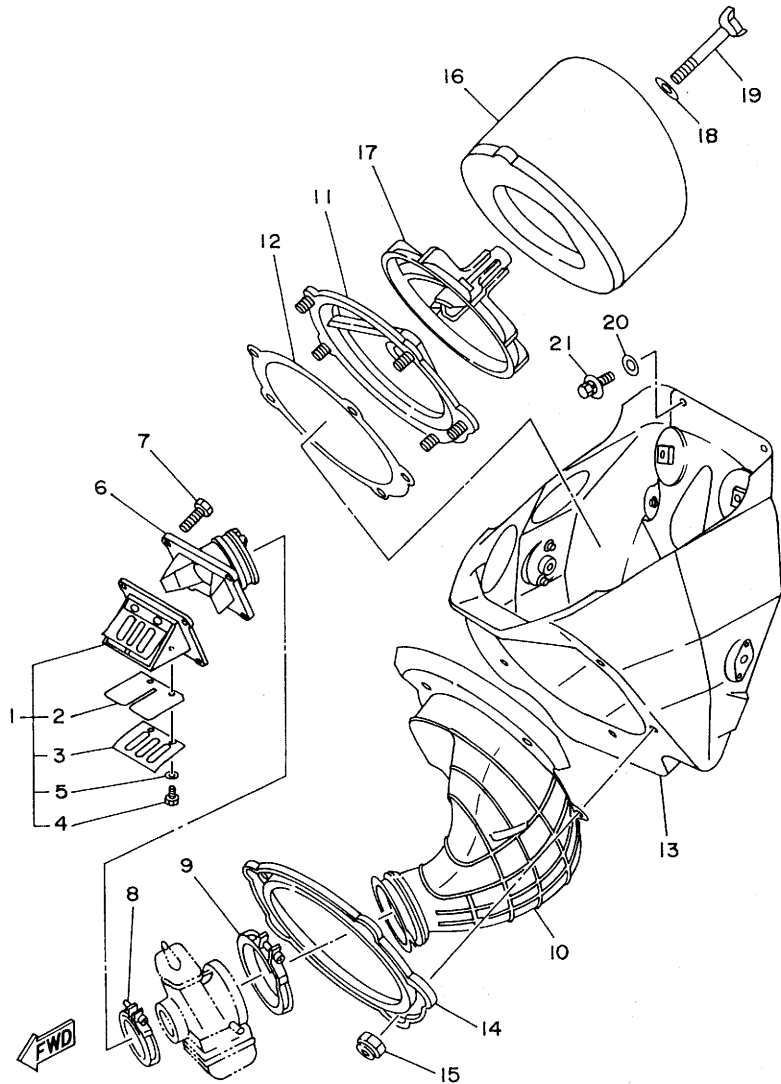

4PE1100-5060

FIG. 7 CARBURETOR

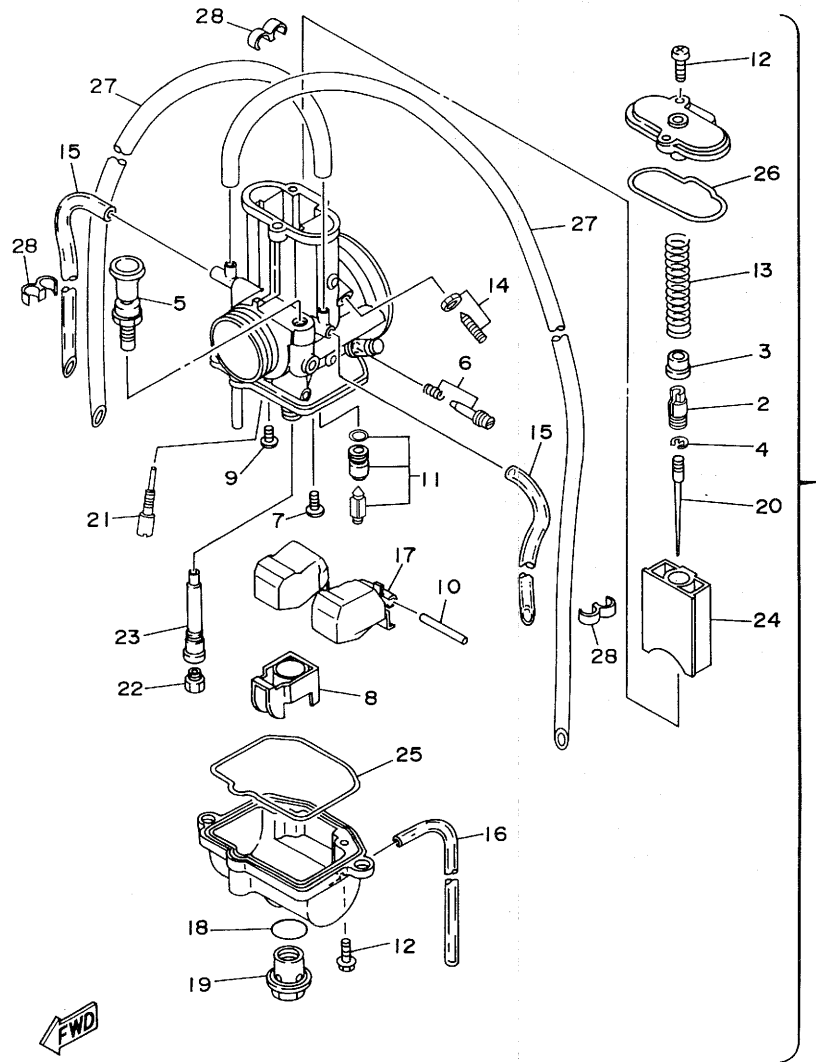

REF. NO.	PART NO.	DESCRIPTION	Q'TY	REMARKS
1	4PE-14101-00	CARBURETOR ASSY 1	1	UR
	4PE-14101-10	CARBURETOR ASSY 1	1	UR FOR EUROPE
	4PE-14101-20	CARBURETOR ASSY 1	1	UR FOR JAPAN
2	4PE-14261-00	.HOLDER	1	
3	4PE-14194-00	.RING	1	
4	256-14919-00	.CLIP	1	
5	3JE-14171-00	.PLUNGER, STARTER	1	
6	3JD-14104-00	.AIR SCREW SET	1	
7	1FN-14565-00	.SCREW	1	
8	4PE-14243-00	.PLATE	1	
9	98507-04008	.SCREW, PAN HEAD	1	
10	353-14186-00	.PIN, FLOAT	1	
11	4PE-14107-38	.NEEDLE VALVE SET	1	
12	98507-04012	.SCREW, PAN HEAD	3	
13	4PE-14131-00	.SPRING, THROTTLE VALVE	1	
14	4PE-14103-00	.THROTTLE SCREW SET	1	
15	2HH-14197-00	.PIPE	2	
16	3X3-14197-00	.PIPE	1	
17	4PE-14185-00	.FLOAT	1	
18	3JE-14561-00	.O-RING	1	
19	3XK-14115-00	.PLUG, SCREW	1	
20	3JD-14116-H0	.NEEDLE (6EG36-63)	1	UR STD
	3JD-14116-H1	.NEEDLE (6EG36-61)	1	AP
	3JD-14116-H2	.NEEDLE (6EG36-62)	1	AP
	3JD-14116-H3	.NEEDLE (6EG36-64)	1	AP
	3JD-14116-H4	.NEEDLE (6EG36-65)	1	AP
21	4KM-14142-55	.JET, PILOT (#55)	1	UR STD
	4KM-14142-50	.JET, PILOT (#50)	1	UR STD FOR EUROPE, JAPAN

4PE1100-5070

B9

FIG. 7 CARBURETOR

REF. NO.	PART NO.	DESCRIPTION	Q'TY	REMARKS
21	4KM-14142-40	.JET, PILOT (#40)	1	AP
	4KM-14142-45	.JET, PILOT (#45)	1	AP
	4KM-14142-60	.JET, PILOT (#60)	1	AP
	4KM-14142-65	.JET, PILOT (#65)	1	AP
22	137-14143-72	.JET, MAIN (#360)	1	UR STD
	137-14143-70	.JET, MAIN (#350)	1	UR STD FOR JAPAN
	137-14143-74	.JET, MAIN (#370)	1	UR STD FOR EUROPE
	137-14143-66-A1	.JET, MAIN (#330)	1	AP
	137-14143-68	.JET, MAIN (#340)	1	AP
	137-14143-76	.JET, MAIN (#380)	1	AP
	137-14143-78	.JET, MAIN (#390)	1	AP
23	3TC-14141-59	.NOZZLE, MAIN (Q-9)	1	UR STD
	3TC-14141-R0	.NOZZLE, MAIN (R-0)	1	UR STD FOR EUROPE, JAPAN
	3TC-14141-57	.NOZZLE, MAIN (Q-7)	1	AP
	3TC-14141-58	.NOZZLE, MAIN (Q-8)	1	AP
	3TC-14141-R1	.NOZZLE, MAIN (R-1)	1	AP
	3TC-14141-R2	.NOZZLE, MAIN (R-2)	1	AP
24	4PE-14112-40	.VALVE, THROTTLE (C.A 4.0)	1	UR STD
	4PE-14112-35	.VALVE, THROTTLE (C.A 3.5)	1	AP
	4PE-14112-45	.VALVE, THROTTLE (C.A 4.5)	1	AP
25	4PE-1416A-00	.O-RING	1	
26	4PE-14147-00	.O-RING	1	
27	4PE-14197-00	.PIPE	2	
28	87M-14137-00	.CLAMP	3	

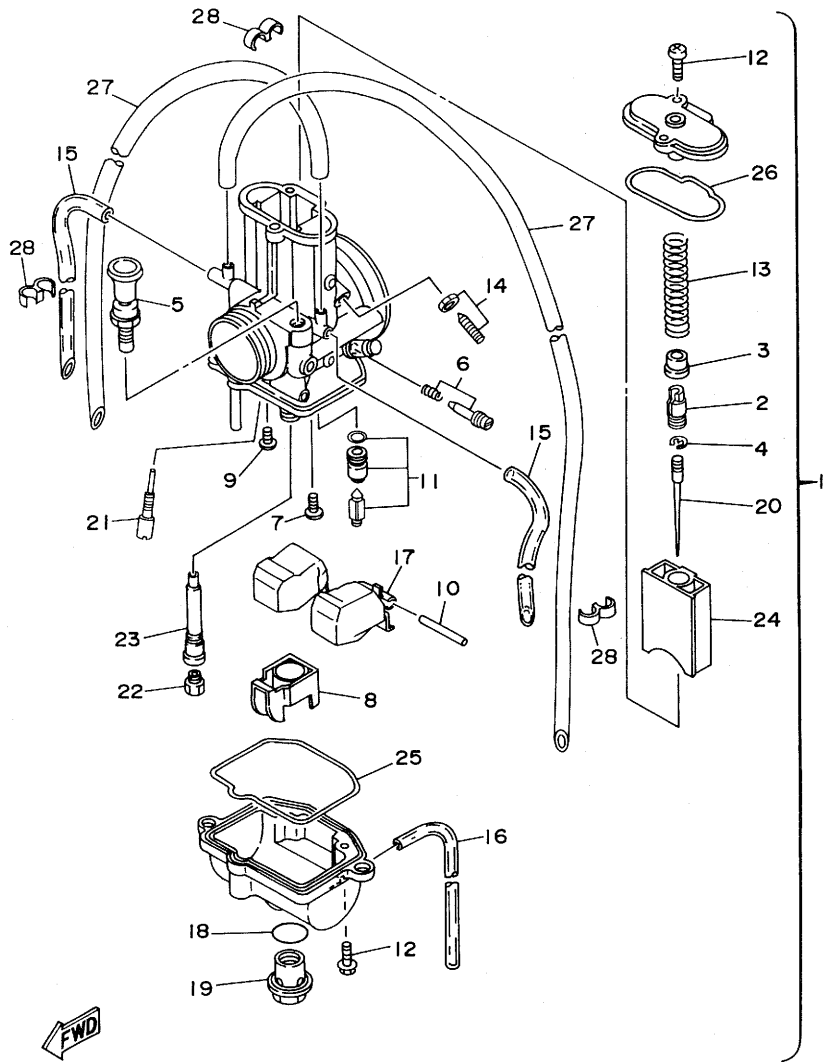

4PE1100-5070

FIG. 8 EXHAUST

REF. NO.	PART NO.	DESCRIPTION	Q'TY	REMARKS
1	4PE-14610-00	EXHAUST PIPE ASSY 1	1	
2	93210-42728	O-RING	2	
3	90507-20052	SPRING, TENSION	2	
4	565-14771-00	STAY, MUFFLER 1	2	
5	95027-06012	BOLT	2	
6	90119-06185	BOLT, WITH WASHER	2	
7	4JY-14615-00	JOINT, EXHAUST 1	1	
8	4JY-14753-01	SILENCER, EXHAUST	1	
9	4JY-1469A-01	.FIBER	1	
10	92017-06010	.SCREW	2	
11	95027-06025	BOLT	1	
12	90387-06363	COLLAR	1	
13	90480-16561	GROMMET	1	
14	90480-10289	GROMMET	1	
15	90387-107R6	COLLAR	1	
16	95027-06016	BOLT	1	

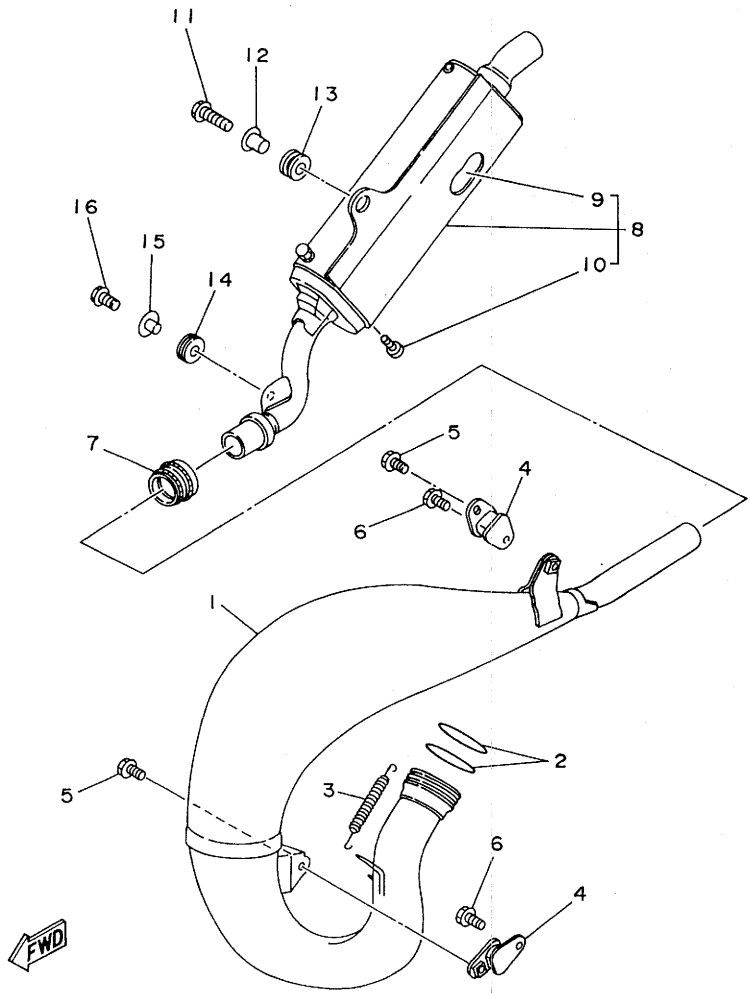

4EP1100-5080

B11

FIG. 9 CRANKCASE

REF. NO.	PART NO.	DESCRIPTION	Q'TY	REMARKS
1	4JY-15111-00	CRANKCASE 1	1	
2	353-13115-01	CONNECTOR, SUCTION PIPE	1	
3	90445-08605	HOSE	1	
4	99510-12016	PIN, DOWEL	2	
5	4JY-15121-00	CRANKCASE 2	1	
6	90387-160H4	COLLAR	2	
7	90340-12097	PLUG, STRAIGHT SCREW	1	
8	90430-12207	GASKET	1	
9	91317-06045	BOLT	4	
10	91317-06055	BOLT	6	
11	91317-06070	BOLT	2	
12	90465-08336	CLAMP	1	

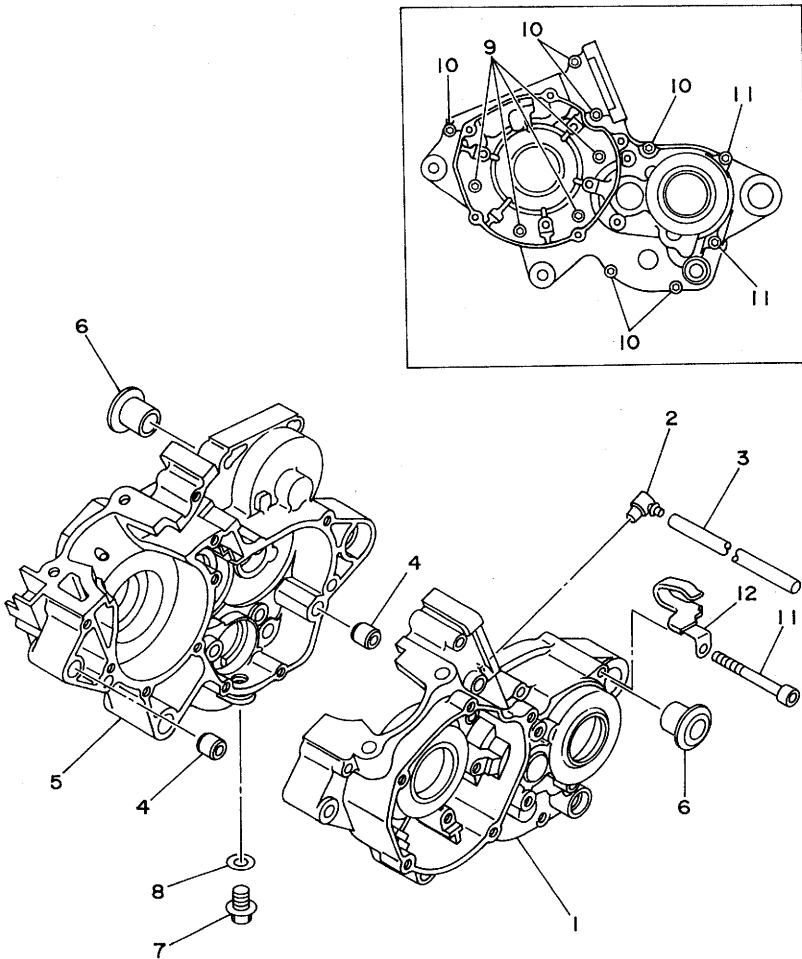

4JY1100-4090

B12

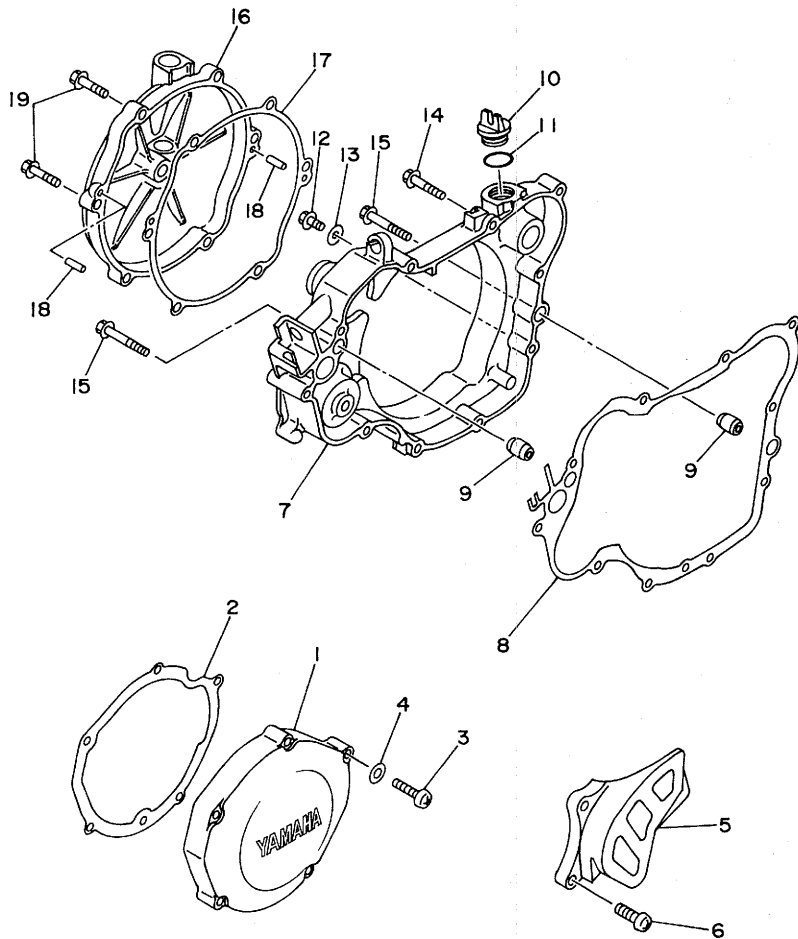

FIG. 10 CRANKCASE COVER 1

REF. NO.	PART NO.	DESCRIPTION	Q'TY	REMARKS
1	4JY-15411-00	COVER, CRANKCASE 1	1	
2	4JY-15451-00	GASKET, CRANKCASE COVER 1	1	
3	98507-06030	SCREW, PAN HEAD	5	
4	92907-06600	WASHER, PLATE	5	
5	4EX-15421-00	COVER, CRANKCASE 2	1	
6	98507-06016	SCREW, PAN HEAD	2	
7	4JY-15431-00	COVER, CRANKCASE 3	1	
8	4JY-15462-00	GASKET, CRANKCASE COVER 3	1	
9	99530-10014	PIN, DOWEL	2	
10	1RG-15363-00	PLUG, OIL	1	
11	93210-19123	O-RING	1	
12	95027-06010	BOLT	1	
13	90430-06014	GASKET	1	
14	95027-06030	BOLT	6	
15	95027-06040	BOLT	2	
16	4JY-15415-00	COVER, GENERATOR	1	
17	4JY-15463-00	GASKET, CARBURETOR COVER 2	1	
18	93604-10011	PIN, DOWEL	2	
19	95027-06025	BOLT	6	



4JY1100-4100

B13

FIG. 11 STARTER

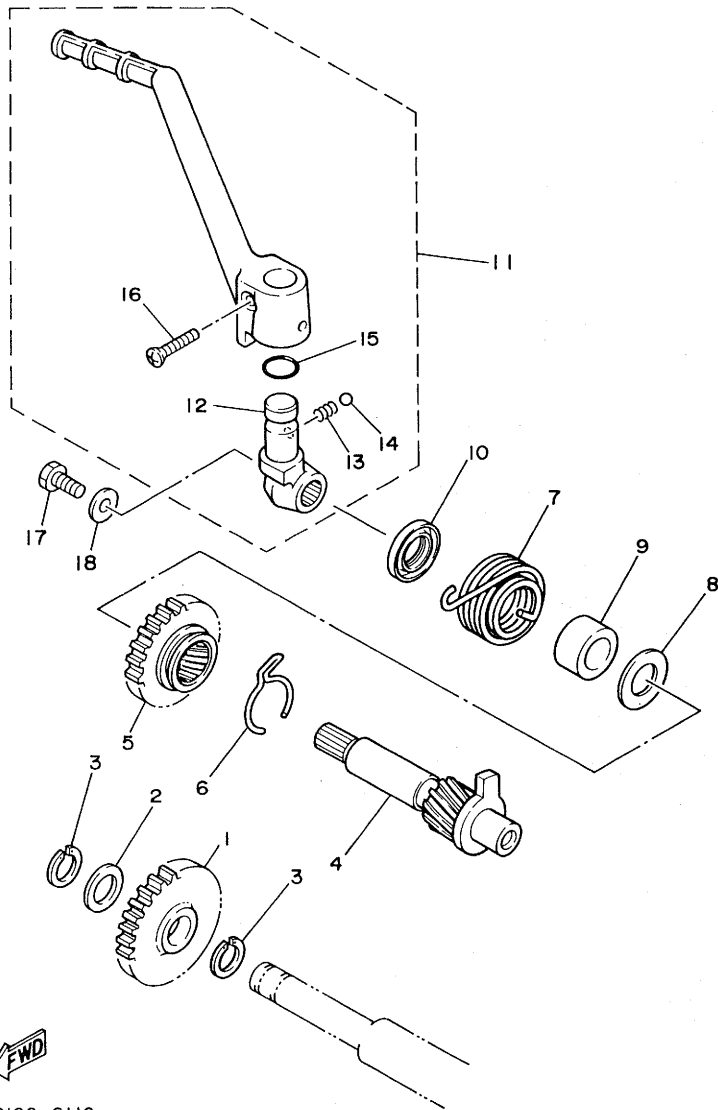

REF. NO.	PART NO.	DESCRIPTION	Q'TY	REMARKS
1	1LX-15651-00	GEAR, KICK IDLE	1	
2	137-17417-00-05	SHIM 1 (0.5T)	1	
3	93440-15012	CIRCLIP	2	
4	1LX-15660-02	KICK AXLE ASSY	1	
5	1LX-15641-00	GEAR, KICK	1	
6	90468-26048	CLIP	1	
7	90508-26450	SPRING, TORSION	1	
8	90201-171G4	WASHER, PLATE	1	
9	90560-17279	SPACER	1	
10	93102-17263	OIL SEAL	1	
11	4DB-15620-03	KICK CRANK ASSY	1	
12	4DB-15621-03	.BOSS, KICK CRANK	1	
13	90501-12081	.SPRING, COMPRESSION	1	
14	93507-32031	.BALL	1	
15	93210-15171	.O-RING	1	
16	90152-06010	.SCREW, COUNTERSUNK	1	
17	97027-06012	BOLT	1	
18	90201-065F3	WASHER, PLATE	1	

FWD

4DB2100-2110

B14

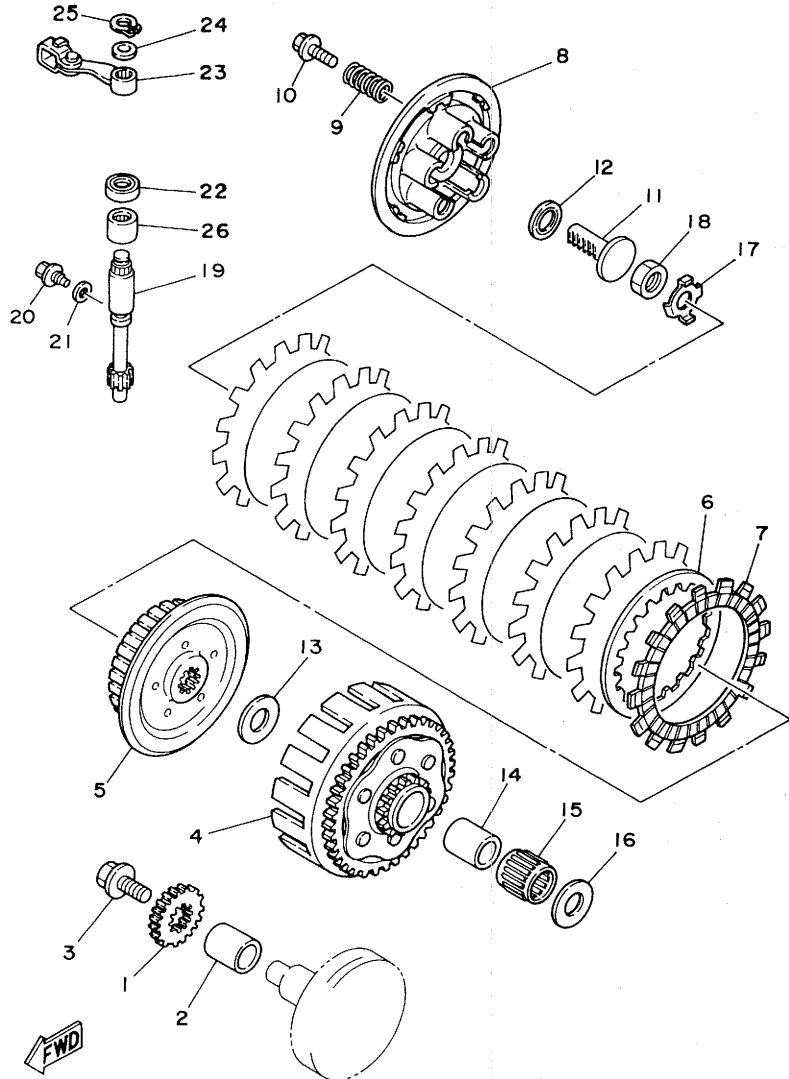

4JY1100-4120

FIG. 12 CLUTCH

REF. NO.	PART NO.	DESCRIPTION	Q'TY	REMARKS
1	3XJ-16111-00	GEAR, PRIMARY DRIVE	1	
2	90387-202T9	COLLAR	1	
3	90105-10445	BOLT, WASHER BASED	1	
4	4JY-16150-00	PRIMARY DRIVEN GEAR COMP.	1	
5	4EX-16371-00	BOSS, CLUTCH	1	
6	3XJ-16324-00	PLATE, CLUTCH 1	7	
7	3XJ-16321-00	PLATE, FRICTION	8	
8	4EX-16351-00	PLATE, PRESSURE 1	1	
9	90501-23598	SPRING, COMPRESSION	5	
10	90159-06016	SCREW, WITH WASHER	5	
11	3SB-16356-00	ROD, PUSH 1	1	
12	93342-21013	BEARING, THRUST	1	
13	90201-204K8	WASHER, PLATE	1	
14	3XJ-16181-00	SPACER 1	1	
15	93310-225N0	BEARING, CYLINDRICAL	1	
16	3XJ-16164-00	PLATE, THRUST 2	1	
17	90215-16245	WASHER, LOCK	1	
18	90170-16326	NUT	1	
19	4EX-16382-00	AXLE, PUSH LEVER	1	
20	90109-06418	BOLT	1	
21	90430-06014	GASKET	1	
22	93102-12224	OIL SEAL	1	
23	3JD-16340-00	PUSH LEVER ASSY	1	
24	90201-10119	WASHER, PLATE	1	
25	99009-10400	CIRCLIP	1	
26	93315-11206	BEARING, CYLINDRICAL	1	

B15

FIG. 13 TRANSMISSION

REF. NO.	PART NO.	DESCRIPTION	Q'TY	REMARKS
1	3XJ-17411-00	AXLE, MAIN	1	
2	4EX-17151-00	GEAR, 5TH PINION	1	
3	4EX-17131-00	GEAR, 3RD PINION	1	
4	4EX-17161-00	GEAR, 6TH PINION	1	
5	3SR-17121-00	GEAR, 2ND PINION	1	
6	90201-22555	WASHER, PLATE	1	
7	90209-18135	WASHER	1	
8	93410-22039	CIRCLIP	3	
9	3XJ-17421-00	AXLE, DRIVE	1	
10	1LX-17211-01	GEAR, 1ST WHEEL	1	
11	4EX-17251-00	GEAR, 5TH WHEEL	1	
12	3SR-17231-00	GEAR, 3RD WHEEL	1	
13	4EX-17241-00	GEAR, 4TH WHEEL	1	
14	4EX-17261-00	GEAR, 6TH WHEEL	1	
15	3XJ-17221-00	GEAR, 2ND WHEEL	1	
16	90201-15701	WASHER, PLATE (1.0T)	1	
17	93440-15012	CIRCLIP	1	
18	90209-18208	WASHER	1	
19	93410-22039	CIRCLIP	2	
20	90201-206K8	WASHER, PLATE	1	
21	93306-30411	BEARING (B6304)	1	
22	93311-41530	BEARING, CYLINDRICAL	1	
23	93306-20469	BEARING	1	
24	1LX-15383-00	PLATE, BEARING COVER	1	
25	98707-06012	SCREW, FLAT HEAD	1	
26	93102-26042	OIL SEAL	1	
27	3XJ-15383-00	PLATE, BEARING COVER	2	
28	98707-06012	SCREW, FLAT HEAD	2	

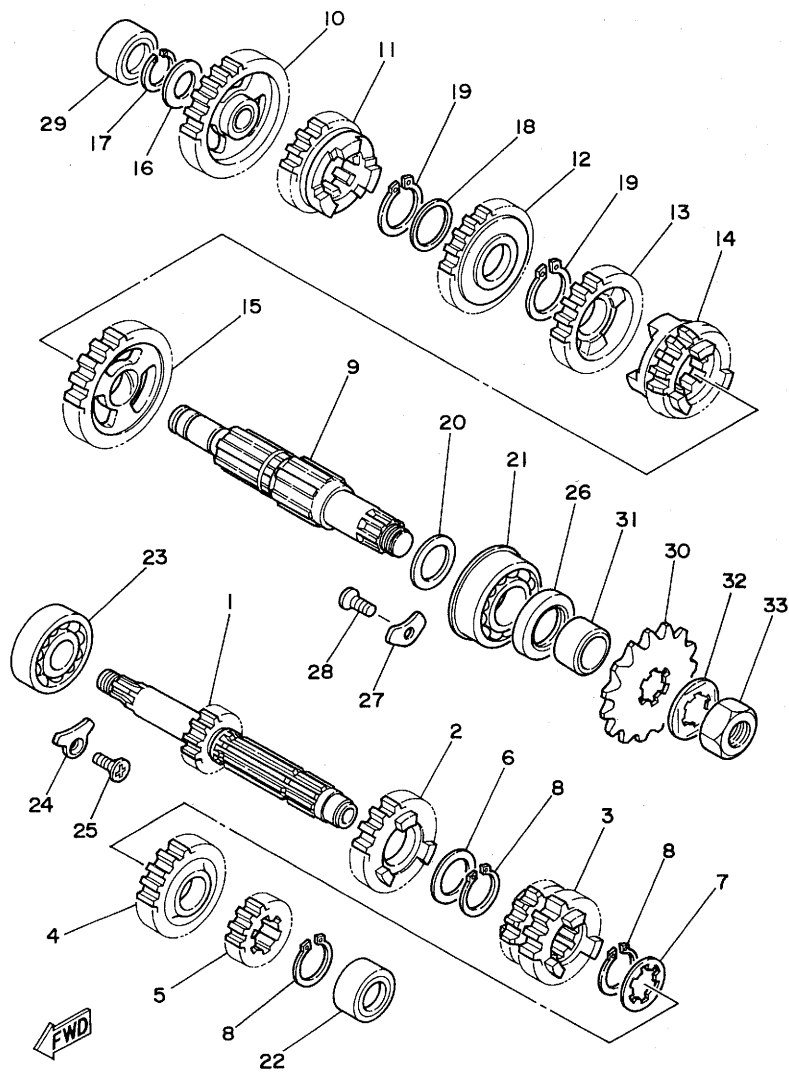

3XJ1100-1130

C2

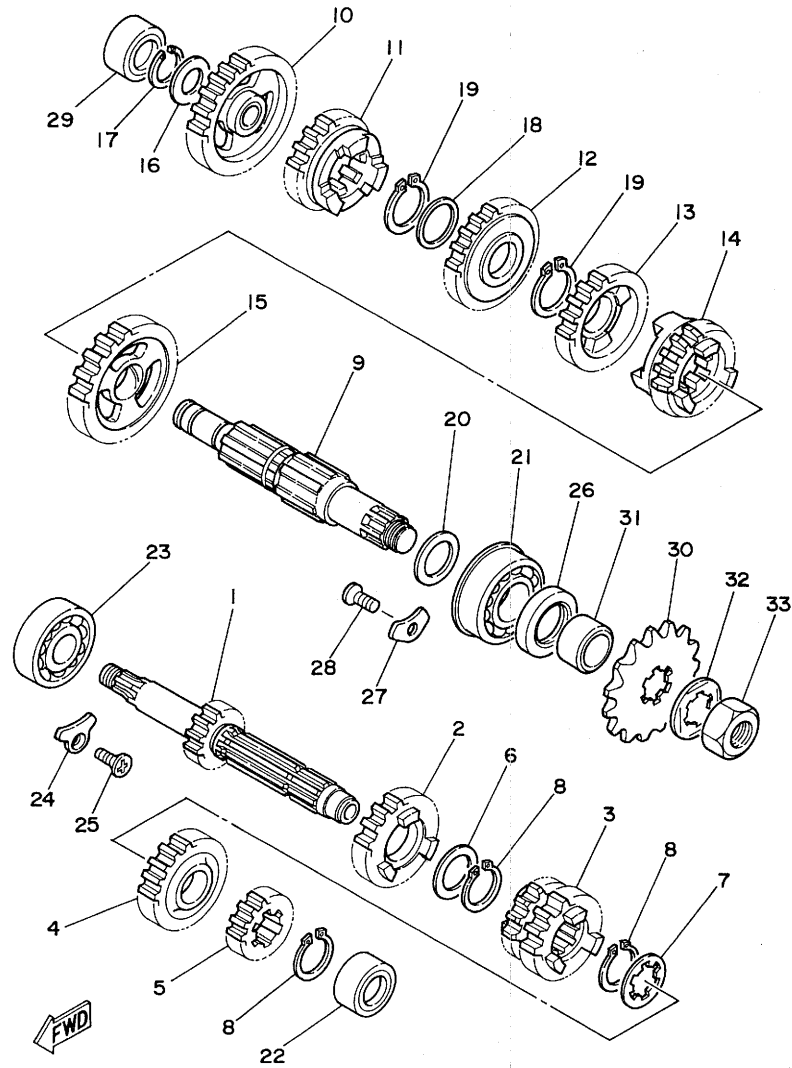

3XJ1100-1130

FIG. 13 TRANSMISSION

REF. NO.	PART NO.	DESCRIPTION	Q'TY	REMARKS
29	93311-31567	BEARING, CYLINDRICAL	1	
30	9383A-13031	SPROCKET, DRIVE 13T (2HG1746130)	1	STD
	9383A-12017	SPROCKET, DRIVE 12T (2HG1746120)	1	AP
	9383A-14054	SPROCKET, DRIVE 14T (2HG1746140)	1	AP
31	90387-202A0	COLLAR	1	
32	90215-20261	WASHER, LOCK	1	
33	90179-16226	NUT	1	

C3

FIG. 14 SHIFT CAM. FORK

REF. NO.	PART NO.	DESCRIPTION	Q'TY	REMARKS
1	4JY-18540-00	SHIFT CAM ASSY	1	
2	4JY-18140-00	STOPPER LEVER ASSY	1	
3	90508-26691	SPRING, TORSION	1	
4	90387-063F7	COLLAR	1	
5	90159-06078	SCREW, WITH WASHER	1	
6	3JD-18511-01	FORK, SHIFT 1	1	
7	2VN-18512-01	FORK, SHIFT 2	1	
8	1LX-18513-01	FORK, SHIFT 3	1	
9	4EX-18531-00	BAR, SHIFT FORK GUIDE 1	1	
10	4EX-18535-00	BAR, SHIFT FORK GUIDE 2	1	

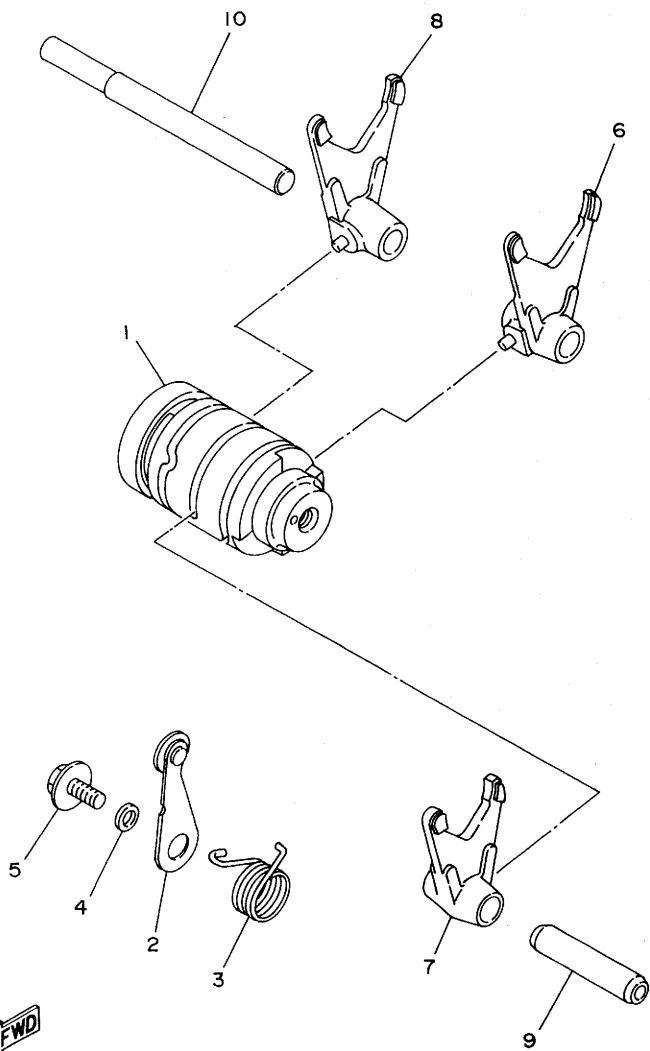

4JY1100-4140

C4

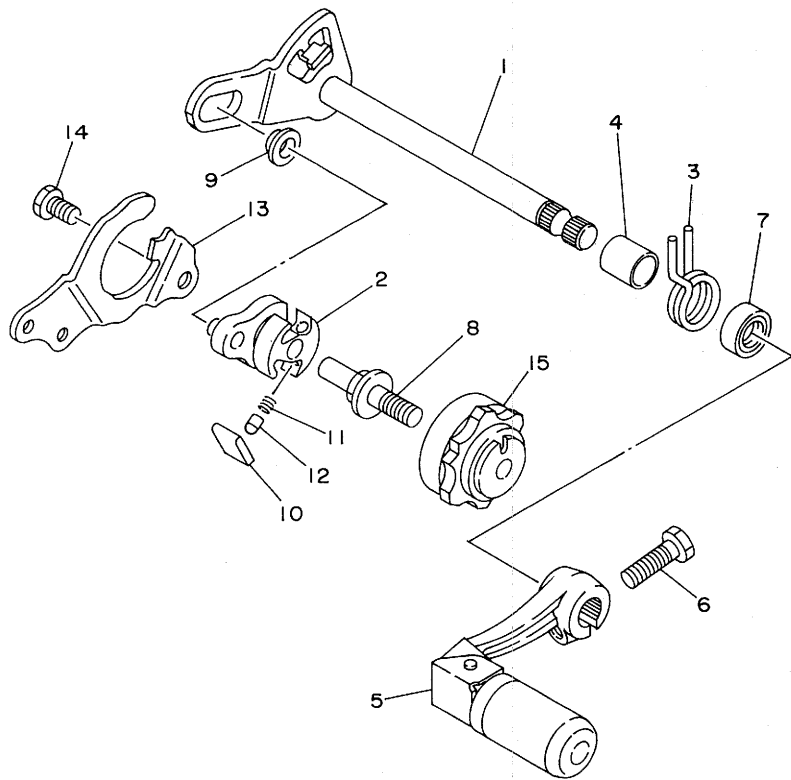

FIG. 15 SHIFT SHAFT

REF. NO.	PART NO.	DESCRIPTION	Q'TY	REMARKS
1	4JY-18101-00	SHIFT SHAFT ASSY	1	
2	3XJ-18122-00	LEVER, SHIFT 2	1	
3	90508-295A7	SPRING, TORSION	1	
4	90560-12280	SPACER	1	
5	1LX-18110-02	SHIFT PEDAL ASSY	1	
6	97027-06025	BOLT	1	
7	93109-12012	OIL SEAL	1	
8	3XJ-18173-00	PIN, SHIFT	1	
9	3XJ-18178-00	ROLLER, SHIFT LEVER	1	
10	3XJ-18182-00	PAWL, SHIFTER	2	
11	90501-052G5	SPRING, COMPRESSION	2	
12	3XJ-18184-00	PIN, PAWL	2	
13	4JY-18172-00	GUIDE, SHIFT	1	
14	90101-06664	BOLT	2	
15	4EW-18185-00	SEGMENT	1	



4JY1100-4150

C5

FIG. 16 FRAME

REF. NO.	PART NO.	DESCRIPTION	Q'TY	REMARKS
1	4PE-21101-00-P0	FRONT FRAME COMP.	1	BLUISH PURPLE SOLID 3
2	4JY-21190-00-P1	REAR FRAME COMP.	1	BLUISH PURPLE SOLID 3
3	90105-08120	BOLT, WASHER BASED	1	
4	90106-08051	BOLT	2	
5	90201-080E2	WASHER, PLATE	2	
6	95027-08040	BOLT	1	
7	4EW-22178-00	TENSIONER	1	
8	93300-60804	BEARING	2	
9	90387-086N4	COLLAR	2	
10	95027-08065	BOLT, FLANGE	1	
11	95317-08700	NUT	1	
12	90201-086P8	WASHER, PLATE	4	
13	3JD-22178-10	TENSIONER	1	
14	95817-08090	BOLT, FLANGE	1	
15	95617-08100	NUT, U	1	
16	90201-08326	WASHER, PLATE	1	
17	90105-10733	BOLT, WASHER BASED	1	
18	95617-10100	NUT, U	1	
19	90201-101J1	WASHER, PLATE	1	
20	4JY-21425-00	BRACKET, REAR UPPER 1	2	
21	95817-08050	BOLT, FLANGE	3	
22	90201-08730	WASHER, PLATE	2	
23	95617-08200	NUT, SELF-LOCKING	3	
24	12R-82591-00	BAND	1	
25	4JY-21274-00	BRACKET, C.D.I. UNIT	1	
26	90105-06452	BOLT, WASHER BASED	1	
27	90201-067J4	WASHER, PLATE	1	
28	56A-28166-00	WRENCH, HEXAGON	1	

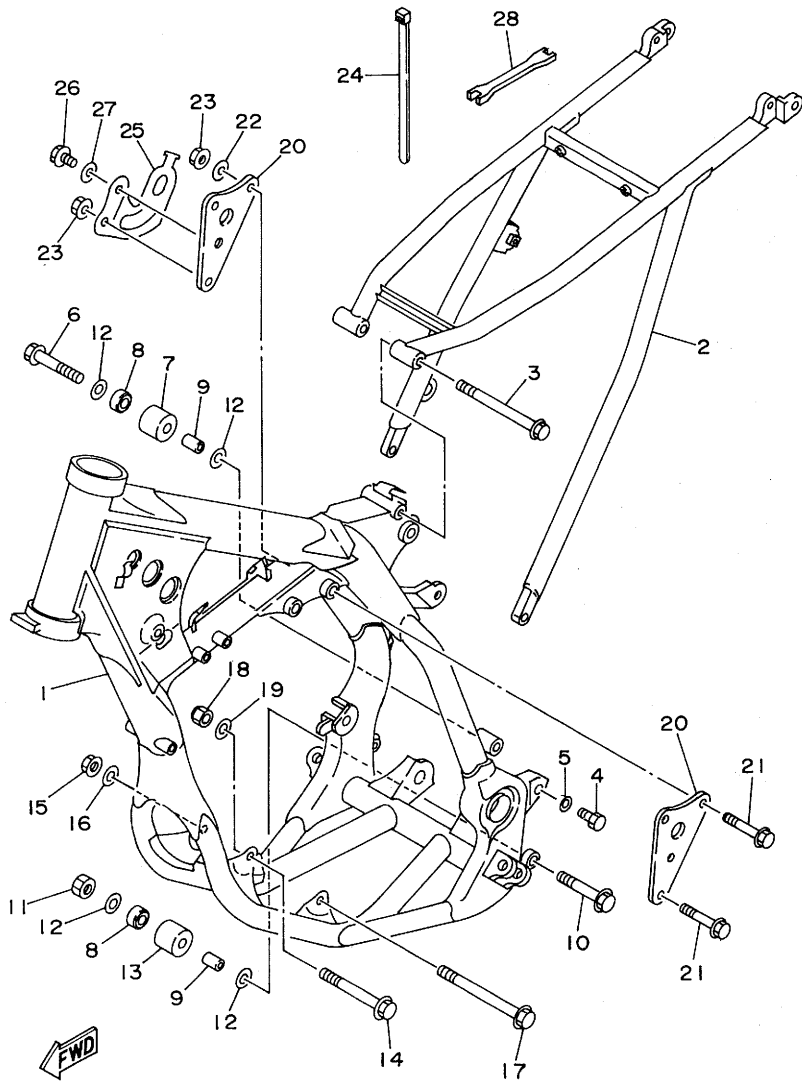

4JY1100-4160

C6

FIG. 17 FENDER

REF. NO.	PART NO.	DESCRIPTION	Q'TY	REMARKS
1	4DA-21511-00	FENDER, FRONT	1	
2	3JD-21748-00	COLLAR	4	
3	90119-06063	BOLT, WITH WASHER	4	
4	4EW-21611-00	FENDER, REAR	1	
5	90119-06185	BOLT, WITH WASHER	2	
6	95027-06016	BOLT	2	
7	90183-06023	NUT, SPRING	2	
8	90387-0701A	COLLAR	2	
9	39X-21642-00	GUARD, FLAP	1	
10	90119-06185	BOLT, WITH WASHER	2	

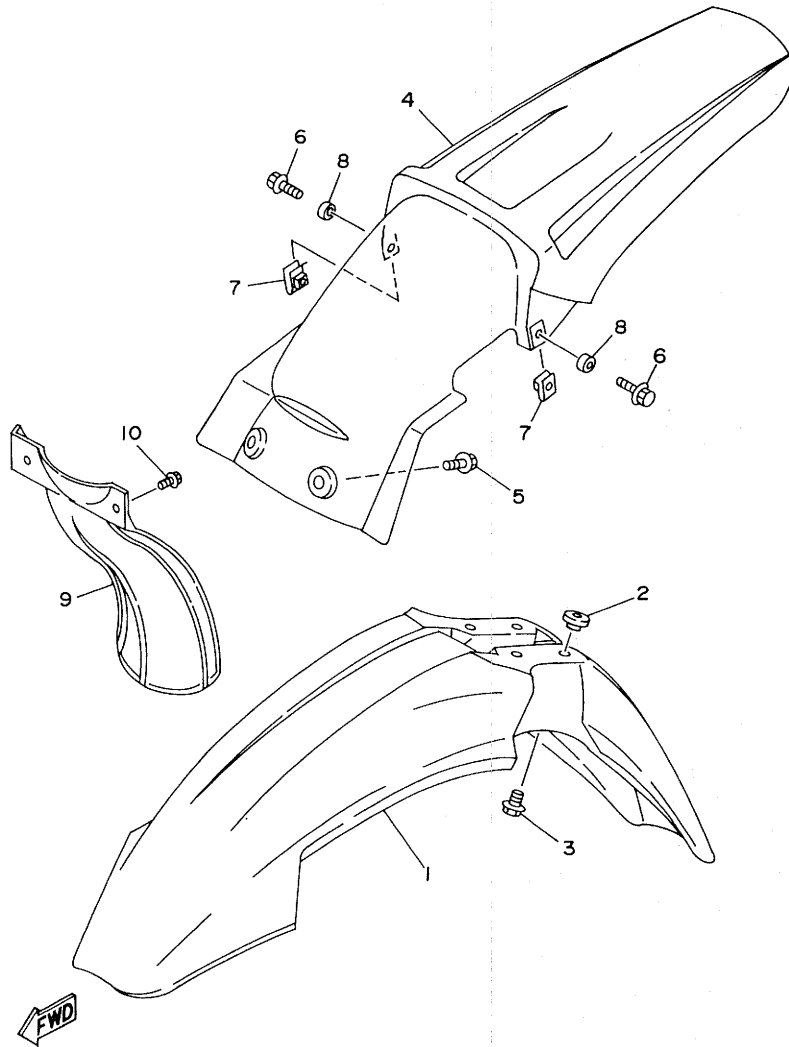

4JY1100-4170

C7

FIG. 18 SIDE COVER

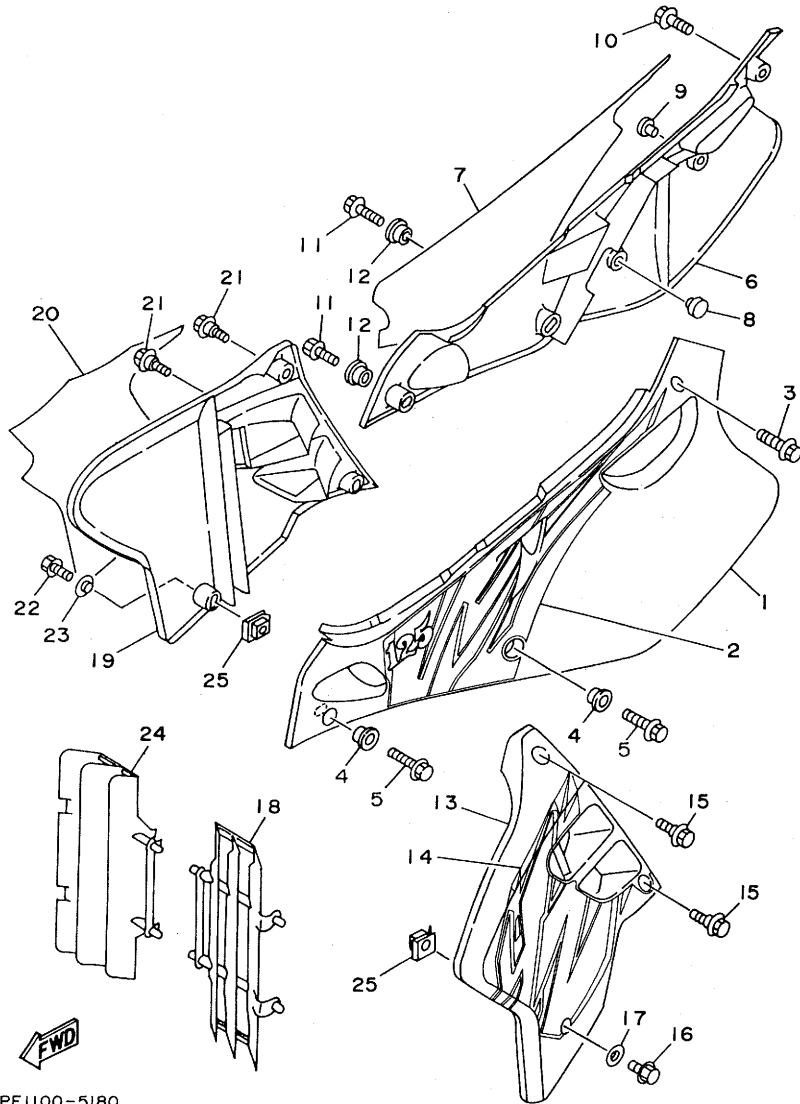

REF. NO.	PART NO.	DESCRIPTION	Q'TY	REMARKS
1	4EW-21711-01	COVER, SIDE 1	1	
2	4PE-2173E-00	GRAPHIC 1	1	
3	90119-06225	BOLT, WITH WASHER	1	
4	90387-0600F	COLLAR	2	
5	95027-06012	BOLT	2	
6	4EW-21721-01	COVER, SIDE 2	1	
7	4PE-2173F-00	GRAPHIC 2	1	
8	22W-24181-00	DAMPER, LOCATING 1	1	
9	90338-10132	PLUG	1	
10	90119-06225	BOLT, WITH WASHER	1	
11	95027-06012	BOLT	2	
12	90387-0600F	COLLAR	2	
13	4EW-21731-00	COVER, SIDE 3	1	
14	4PE-21783-00	EMBLEM	1	
15	90109-067F4	BOLT	2	
16	95027-06014	BOLT, FLANGE	1	
17	90387-0603J	COLLAR	1	
18	4EW-2172A-00	PANEL 1	1	
19	4EW-21741-00	COVER, SIDE 4	1	
20	4PE-2173G-00	EMBLEM SET 1	1	
21	90109-067F4	BOLT	2	
22	95027-06014	BOLT, FLANGE	1	
23	90387-0603J	COLLAR	1	
24	4EW-2172A-00	PANEL 1	1	
25	90183-06069	NUT, SPRING	2	

4PE1100-5180

FIG. 19 REAR ARM

REF. NO.	PART NO.	DESCRIPTION	Q'TY	REMARKS
1	4EW-22110-02	REAR ARM COMP.	1	
2	90151-04048	SCREW, COUNTERSUNK	8	
3	4JX-22355-01	PATCH A	2	
4	93317-22262	BEARING, CYLINDRICAL	4	
5	90338-10150	PLUG	2	
6	93106-22019	OIL SEAL (DC 22-28-8)	2	
7	93342-22215	BEARING, THRUST	2	
8	4EW-22129-00	COVER, THRUST 2	2	
9	90380-16158	BUSH, SOLID	2	
10	156-22127-00	SHIM (0.3T)	1 UN	
11	4EW-22151-01	SEAL, GUARD	1	
12	90110-05201	BOLT, HEXAGON SOCKET HEAD	4	
13	4EW-22199-01	SUPPORT, CHAIN	1	
14	4MX-22128-00	COVER, THRUST 1	1	
15	95027-06045	BOLT, FLANGE	2	
16	90179-06568	NUT	2	
17	95027-06010	BOLT	1	
18	1LX-22141-00	SHAFT, PIVOT	1	
19	90185-16127	NUT, SELF-LOCKING	1	
20	90201-164H4	WASHER, PLATE	1	
21	4EW-2217A-00	ARM, RELAY	1	
22	93315-22046	BEARING, CYLINDRICAL	2	
23	93109-20029	OIL SEAL	4	
24	90387-164N2	COLLAR	2	
25	90387-164N3	COLLAR	2	
26	90387-167Y9	COLLAR	1	
27	90109-147F2	BOLT	1	
28	90109-142F4	BOLT	2	

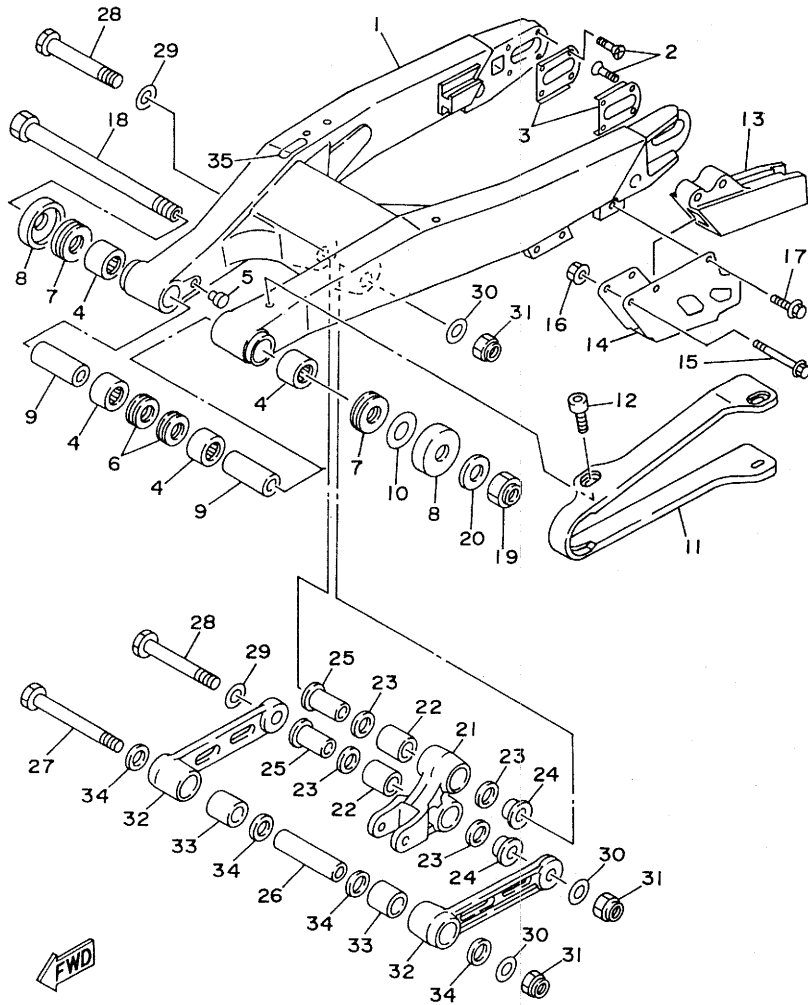

4PE1100-5190

C9

FIG. 19 REAR ARM

REF. NO.	PART NO.	DESCRIPTION	Q'TY	REMARKS
29	90201-164H4	WASHER, PLATE	2	
30	90201-14740	WASHER, PLATE	3	
31	90185-14070	NUT, SELF-LOCKING	3	
32	4EW-2217F-00	ROD, CONNECTING 1	2	
33	93315-22046	BEARING, CYLINDRICAL	2	
34	93109-20029	OIL SEAL	4	
35	46X-21269-00	SEAL	1	

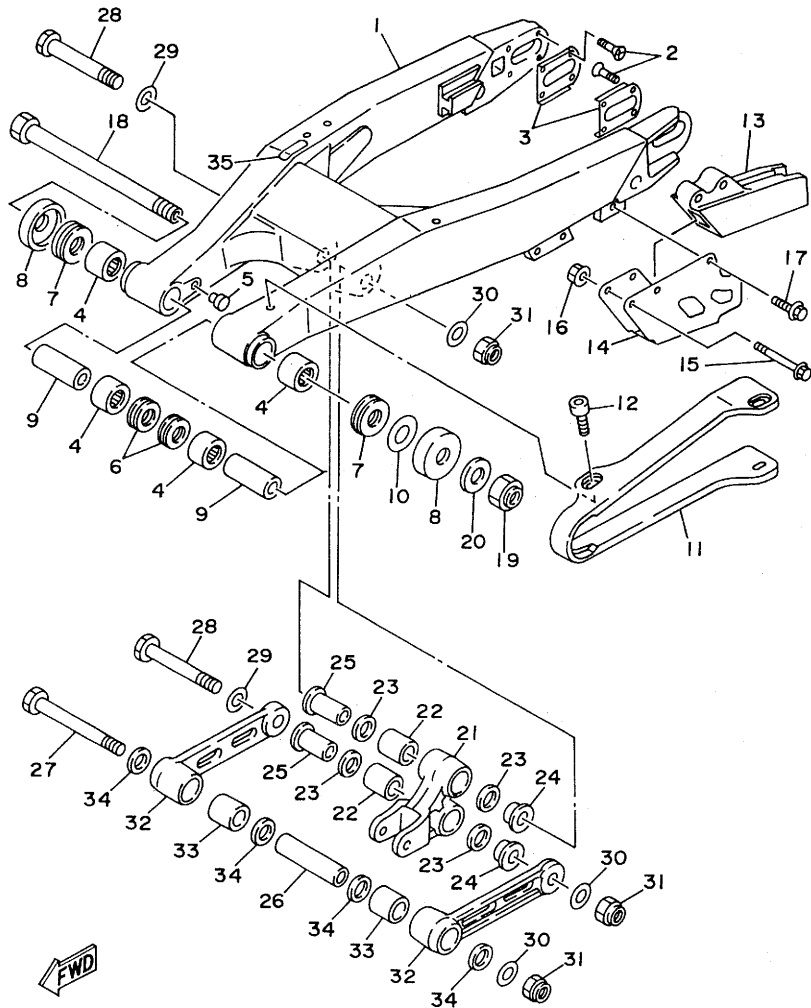

4PE1100-5190

FIG. 20 REAR SUSPENSION

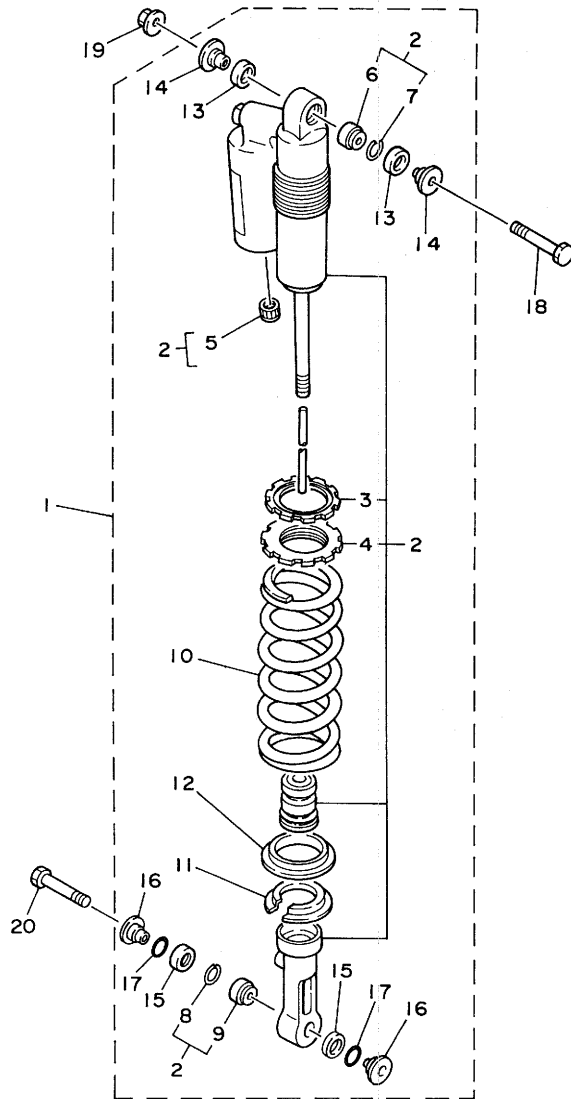

REF. NO.	PART NO.	DESCRIPTION	Q'TY	REMARKS
1	4PE-22210-10	SHOCK ABSORBER ASSY, REAR	1	UR FOR U.S.A.
	4PE-22210-00	SHOCK ABSORBER ASSY, REAR	1	UR FOR EUROPE, OCEANIA, S.AFRICA
	4PE-22210-20	SHOCK ABSORBER ASSY, REAR	1	UR FOR JAPAN
	4PE-22210-30	SHOCK ABSORBER ASSY, REAR	1	UR FOR CANADA
2	4MX-22201-10	.DAMPER SUB ASSY	1	UR FOR U.S.A.
	4MX-22201-00	.DAMPER SUB ASSY	1	UR FOR EUROPE, OCEANIA, S.AFRICA
	4PE-22201-20	.DAMPER SUB ASSY	1	UR FOR JAPAN
	4MX-22201-30	.DAMPER SUB ASSY	1	UR FOR CANADA
3	3SP-22234-00	..GUIDE, SPRING 3	1	
4	3SP-22213-00	..SEAT, SPRING UPPER	1	
5	24M-23184-00	..CAP, AIR VALVE	1	
6	4MX-22216-00	..BUSH, REAR SHOCK ABSORBER	1	
7	43M-22274-00	..RING, STOP	1	
8	3Y6-23183-00	..CIRCLIP	1	
9	4JX-22226-00	..BUSH, SHOCK ABSORBER LOWER	1	
10	4JW-22212-20	.SPRING (K=4.6)	1	
11	3JD-22214-00	.GUIDE, SPRING 1	1	
12	3JD-22224-00	.GUIDE, SPRING 2	1	
13	3JD-22475-00	.SEAL, DUST	2	
14	3XJ-22253-00	.COLLAR, DISTANCE	2	
15	3JE-22475-00	.SEAL, DUST	2	
16	4EW-22253-00	.COLLAR, DISTANCE	2	
17	4EW-22474-00	.SEAL, RING	2	
18	3SP-22241-00	BOLT 1	1	
19	95617-10200	NUT, SELF-LOCKING	1	
20	90105-10614	BOLT, WASHER BASED	1	

FWD
4JX1100-4200

C11

FIG. 21 STEERING

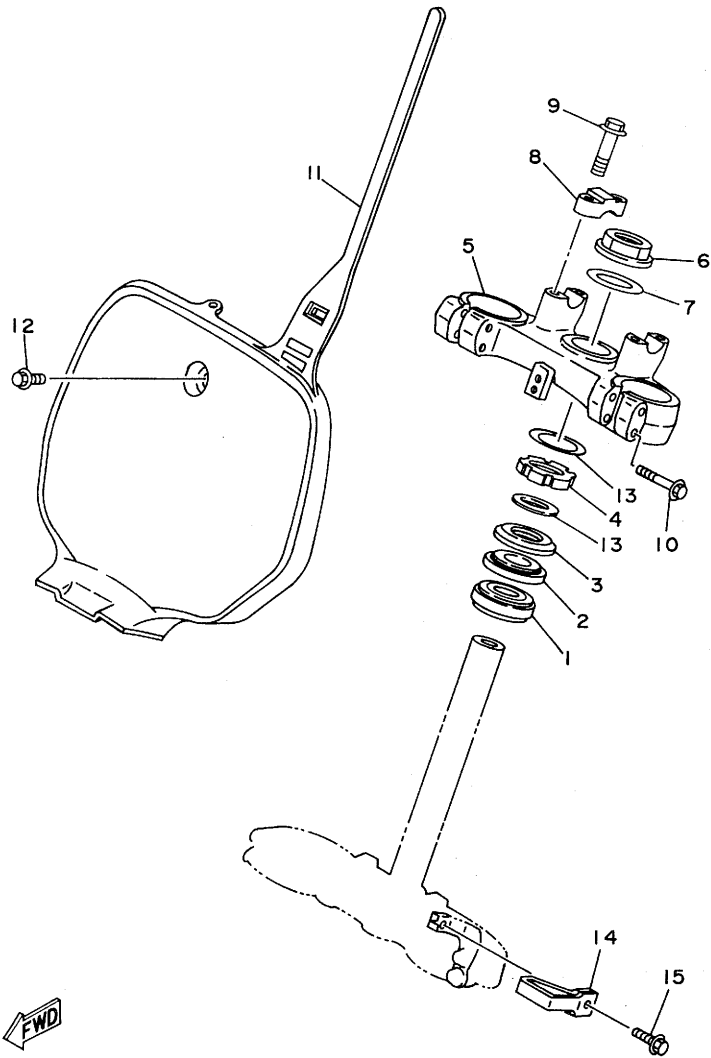

REF. NO.	PART NO.	DESCRIPTION	Q'TY	REMARKS
1	93332-00078	BEARING	1	
2	93332-00068	BEARING	1	
3	4EW-23416-00	COVER, BALL RACE 2	1	
4	90179-28650	NUT	1	
5	4JX-23435-00	CROWN, HANDLE	1	
6	90170-24373	NUT	1	
7	90201-247L2	WASHER, PLATE	1	
8	3SP-23441-00	HOLDER, HANDLE UPPER	2	
9	95027-08035	BOLT	4	
10	95027-08040	BOLT	4	
11	4DA-23485-01	PLATE, NUMBER	1	
12	90119-06185	BOLT, WITH WASHER	1	
13	90201-286K9	WASHER, PLATE	2	
14	4DA-23389-00	GUIDE, CABLE	1	
15	90105-05361	BOLT, WASHER BASED	1	

4JX1100-4210

C12

FIG. 22 FRONT FORK

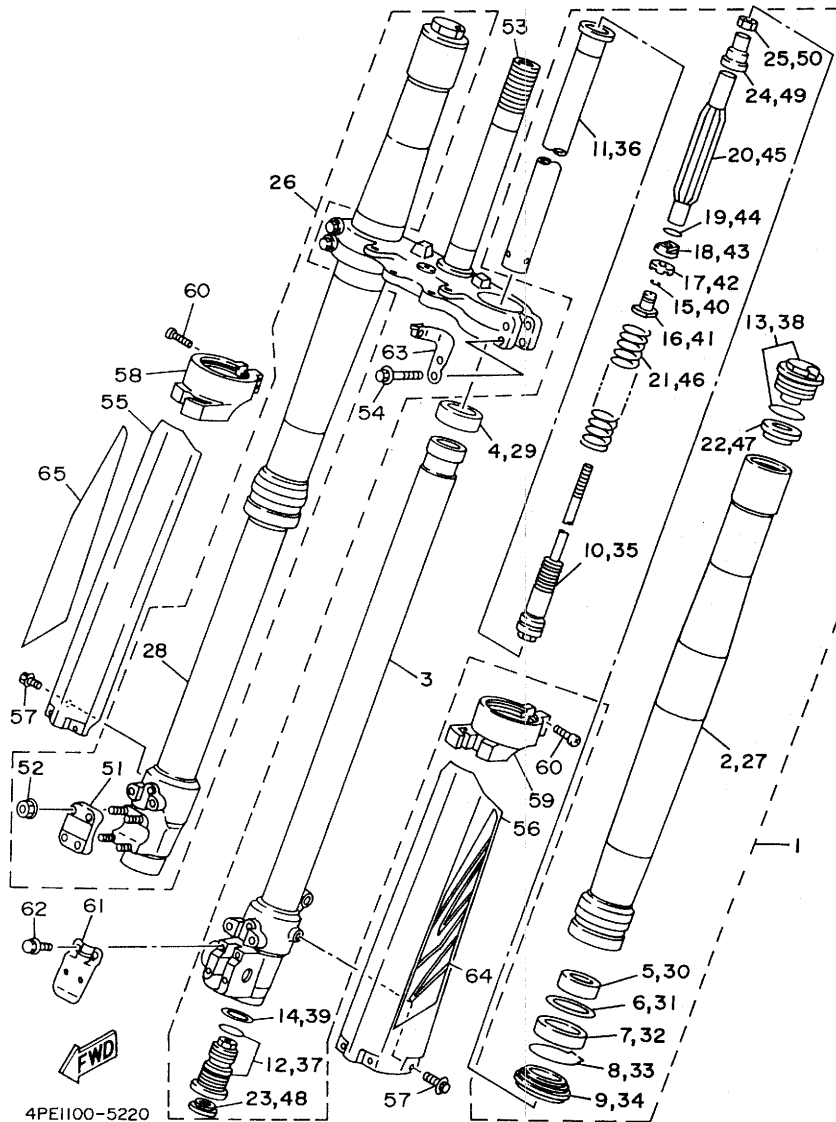

REF. NO.	PART NO.	DESCRIPTION	Q'TY	REMARKS
1	4PE-23102-LO	FRONT FORK ASSY (L.H)	1	
2	4MX-23136-LO	.TUBE, OUTER (RIGHT)	1	
3	4EW-23120-LO	.INNER TUBE COMP. 2	1	
4	3XJ-23171-LO	.PISTON, FRONT FORK	1	
5	4EW-23125-LO	.METAL, SLIDE 1	1	
6	4V4-23146-LO	.WASHER, OIL SEAL	1	
7	3XJ-23145-LO	.OIL SEAL	1	
8	4V4-23153-LO	.RING, SNAP	1	
9	4DA-23144-LO	.SEAL, DUST	1	
10	4MX-2314A-LO	.PISTON ROD ASSY	1	
11	4MX-23170-LO	.CYLINDER COMP., FRONT FORK	1	
12	4PE-2316A-LO	.VALVE COMP.	1	
13	4EW-23111-LO	.BOLT, CAP	1	
14	3JD-23158-LO	.GASKET	1	
15	3SP-23153-LO	.RING, SNAP	2	
16	3SP-23113-LO	.COLLAR	1	
17	3SP-23166-LO	.SPACER, OIL LOCK	1	
18	3SP-23393-LO	.NUT, SPECIAL	1	
19	3JD-23147-LO	.O-RING	1	
20	4JX-23142-LO	.SEAT, SPRING UPPER	1	
21	3XK-23141-LO	.SPRING, FRONT FORK (K=0.390)	1	
22	3XJ-23143-LO	.SEAT, SPRING LOWER	1	
23	3JD-2312G-LO	.PLUG	1	
24	4JX-23363-LO	.COLLAR 1	1	
25	3SP-23357-LO	.NUT	1	
26	4PE-23103-LO	FRONT FORK ASSY (R.H)	1	
27	4MX-23136-LO	.TUBE, OUTER (RIGHT)	1	
28	4EW-23110-LO	.INNER TUBE COMP. 1	1	

FIG. 22 FRONT FORK

REF. NO.	PART NO.	DESCRIPTION	QTY	REMARKS
29	3XJ-23171-L0	.PISTON, FRONT FORK	1	
30	4EW-23125-L0	.METAL, SLIDE 1	1	
31	4V4-23146-L0	.WASHER, OIL SEAL	1	
32	3XJ-23145-L0	.OIL SEAL	1	
33	4V4-23153-L0	.RING, SNAP	1	
34	4DA-23144-L0	.SEAL, DUST	1	
35	4MX-2314A-L0	.PISTON ROD ASSY	1	
36	4MX-23170-L0	.CYLINDER COMP., FRONT FORK	1	
37	4PE-2316A-L0	.VALVE COMP.	1	
38	4EW-23111-L0	.BOLT, CAP	1	
39	3JD-23158-L0	.GASKET	1	
40	3SP-23153-L0	.RING, SNAP	2	
41	3SP-23113-L0	.COLLAR	1	
42	3SP-23166-L0	.SPACER, OIL LOCK	1	
43	3SP-23393-L0	.NUT, SPECIAL	1	
44	3JD-23147-L0	.O-RING	1	
45	4JX-23142-L0	.SEAT, SPRING UPPER	1	
46	3XK-23141-L0	.SPRING, FRONT FORK (K=0.390)	1	
47	3XJ-23143-L0	.SEAT, SPRING LOWER	1	
48	3JD-23126-L0	.PLUG	1	
49	4JX-23363-L0	.COLLAR 1	1	
50	3SP-23357-L0	.NUT	1	
51	4EW-23167-L0	.HOLDER, AXLE	1	
52	2KF-23127-01	.NUT	4	
53	4PE-23340-L0	UNDER BRACKET COMP.	1	
54	95023-08040	BOLT	4	
55	4MX-2314J-L0	PROTECTOR COMP. 2	1	
56	4MX-2314H-L1	PROTECTOR COMP. 1	1	

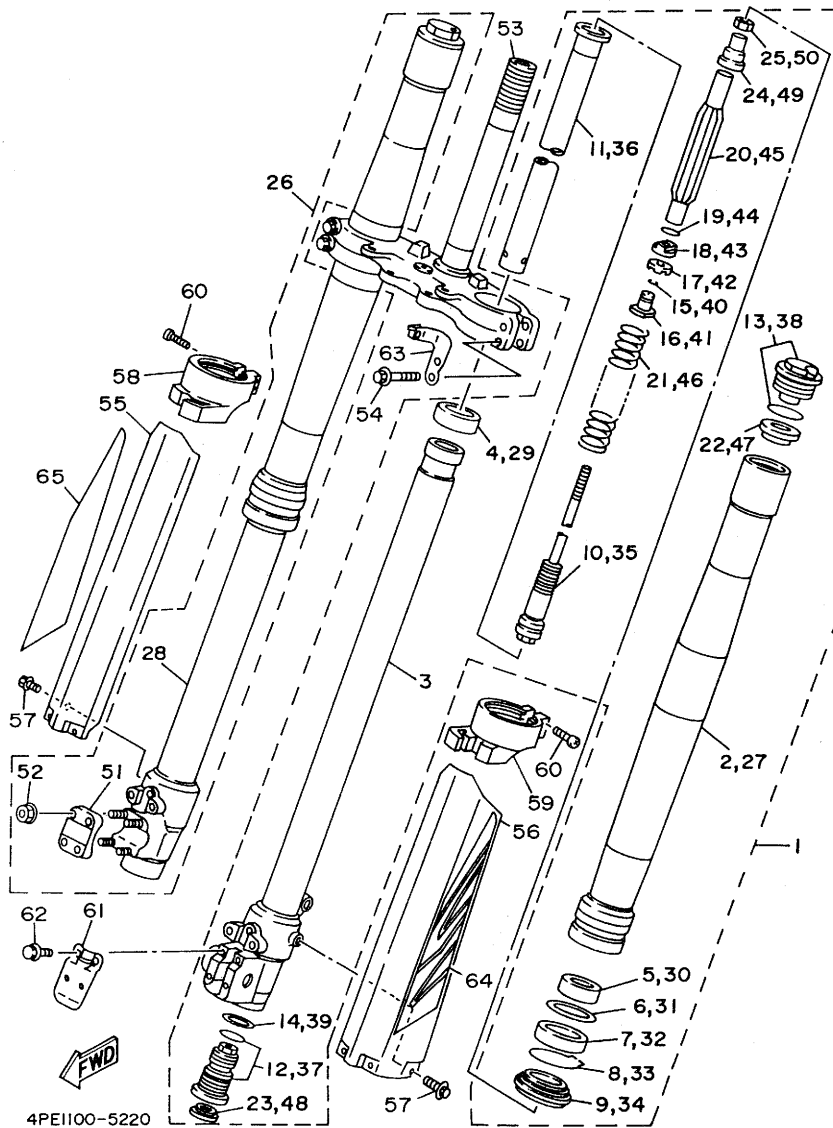

FIG. 22 FRONT FORK

REF. NO.	PART NO.	DESCRIPTION	Q'TY	REMARKS
----------	----------	-------------	------	---------

57	3SP-23356-LO	BOLT 2	6	
58	4MX-2314G-LO	PROTECTOR GUIDE COMP. 2	1	
59	4MX-2314F-LO	PROTECTOR GUIDE COMP. 1	1	
60	98511-04020	SCREW, PAN HEAD	4	
61	4EW-2314E-LO	COVER, HOSE	1	
62	4DA-23346-LO	BOLT 1	4	
63	4EW-2331E-LO	GUIDE, CABLE	1	
64	4PE-2313B-00	EMBLEM 1	1	
65	4PE-2313C-00	EMBLEM 2	1	

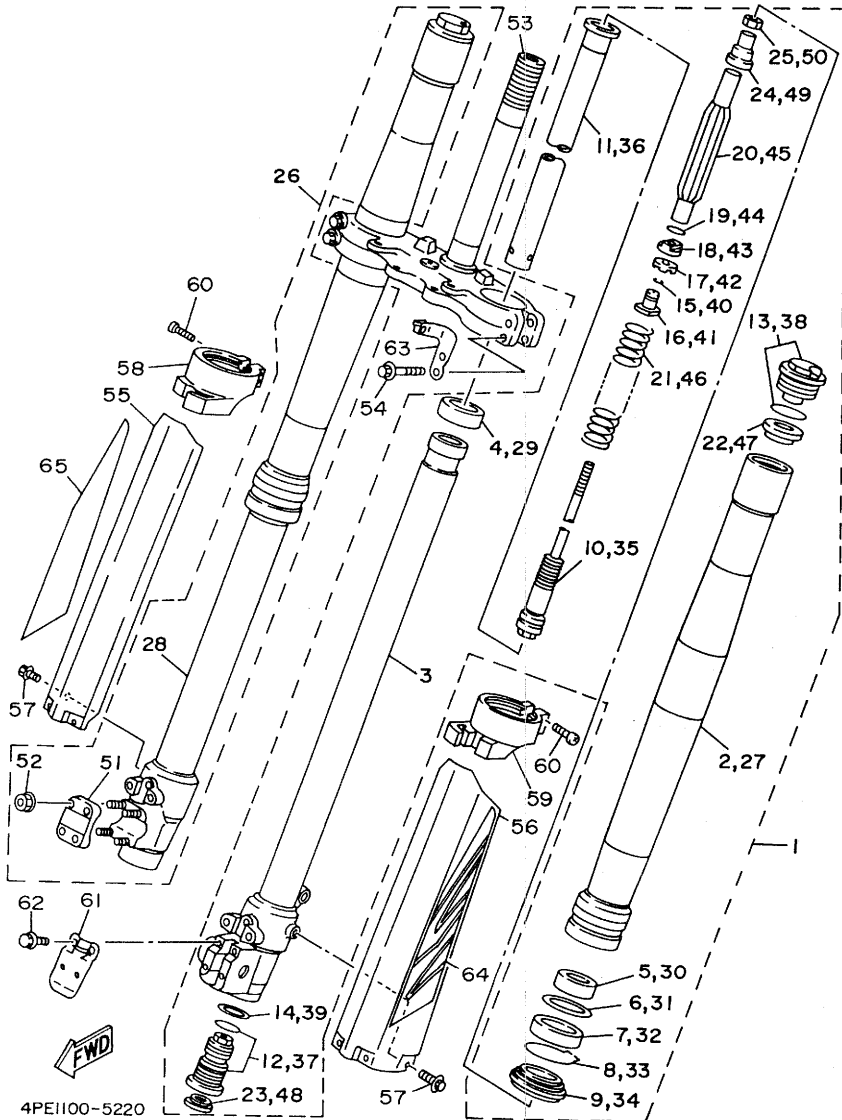
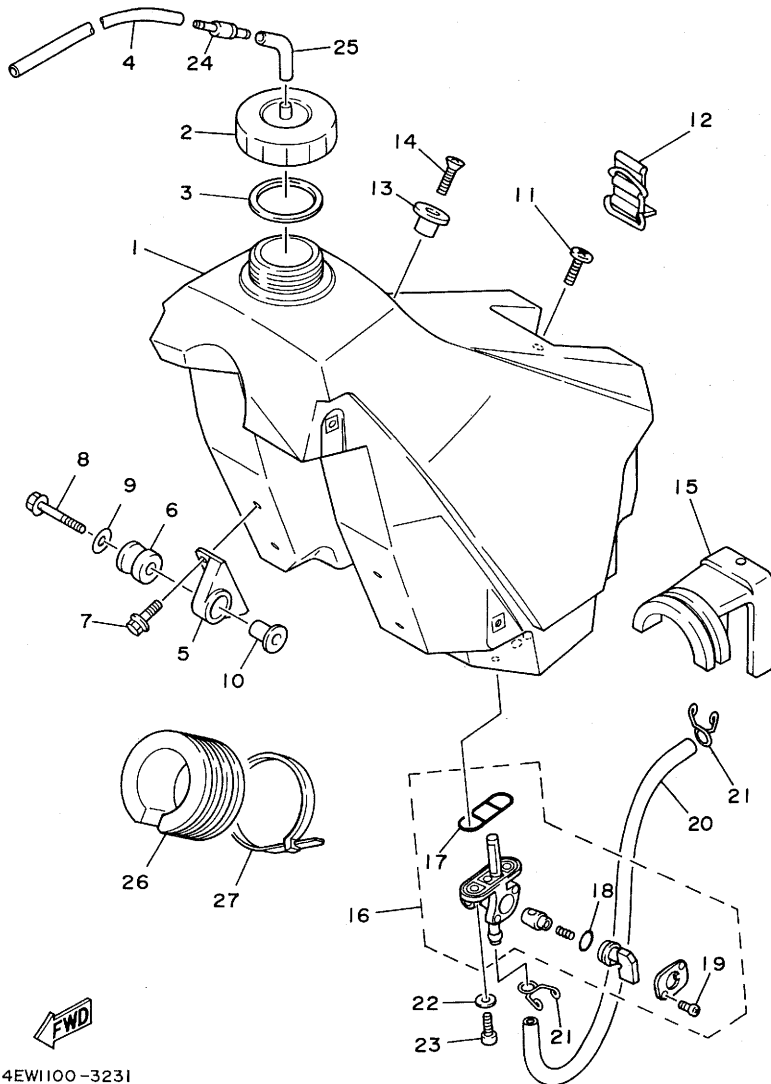

FIG. 23 FUEL TANK



REF. NO.	PART NO.	DESCRIPTION	Q'TY	REMARKS
1	4EW-24110-00	FUEL TANK COMP.	1	
2	5X7-24611-01	BODY, CAP	1	
3	5X7-24612-00	GASKET, CAP	1	
4	90445-09100	HOSE	1	
5	24X-24144-00	HOLDER, DAMPER	2	
6	90480-18549	GROMMET	2	
7	95027-06016	BOLT	4	
8	95027-06035	BOLT	2	
9	90201-06697	WASHER, PLATE	2	
10	3JD-24186-00	WASHER, SPECIAL	2	
11	98907-06020	SCREW, BIND	1	
12	3SP-24173-00	BAND, TANK FITTING 1	1	
13	4EW-2412F-00	BRACKET, SEAT	1	
14	98707-06025	SCREW, FLAT HEAD	1	
15	4EW-24181-00	DAMPER, LOCATING 1	1	
16	3JD-24500-01	FUEL COCK ASSY 1	1	
17	4X8-24512-00	.O-RING	1	
18	3AJ-24534-00	.SEAL, COCK	1	
19	98503-03008	.SCREW, PAN HEAD	2	
20	90445-111J0	HOSE	1	
21	90467-10008	CLIP	2	
22	90202-05187	WASHER, PLATE	2	
23	90149-06011	SCREW	2	
24	3XJ-24380-00	PIPE JOINT ASSY	1	
25	90445-09058	HOSE	1	
26	4EW-24182-00	DAMPER, LOCATING 2	1	
27	90464-14117	CLAMP	1	

4EW1100-3231

D2

FIG. 24 SEAT

REF. NO.	PART NO.	DESCRIPTION	Q'TY	REMARKS
1	4MX-24770-00	SEMI-DOUBLE SEAT ASSY	1	
2	4MX-24731-00	.COVER, SEAT	1	
3	4EW-24728-00	.BRACKET, SEAT	1	
4	4EW-24738-00	.BRACKET, SEAT	1	
5	95027-06016	.BOLT	4	

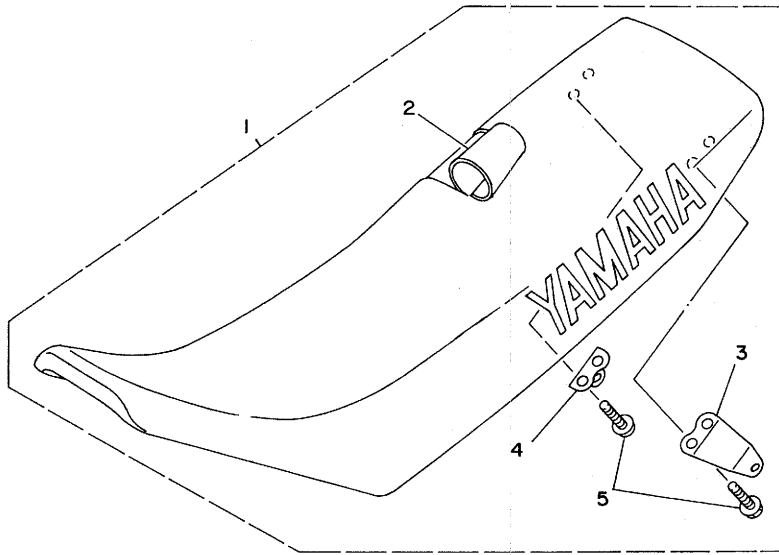

4EW1100-3241

D3

FIG. 25 FRONT WHEEL

REF. NO.	PART NO.	DESCRIPTION	Q'TY	REMARKS
1	4EW-25111-00	HUB, FRONT	1	
2	93306-00316	BEARING	2	
3	90560-17379	SPACER	1	
4	93106-22032	OIL SEAL	2	
5	146-25116-00	FLANGE, SPACER 2	1	
6	94416-21509	RIM (1.60-21)	1	
7	4DA-25104-00	SPOKE SET, FRONT	1	
8	94108-217X2	TIRE (80/100-21 K490)	1	UR DUNLOP
	94108-2102V	TIRE (80/100-21 51M D752F)	1	UR DUNLOP FOR EUROPE
9	94227-21123	TUBE (2.75-21)	1	BRIDGESTONE
10	94307-21145	BAND, RIM (70-80/100-21)	1	DUNLOP
11	5X2-25394-00	SPACER, BEAD	1	
12	4DA-25181-00	AXLE, WHEEL	1	
13	90387-173Y0	COLLAR	1	
14	90387-172Y9	COLLAR	1	

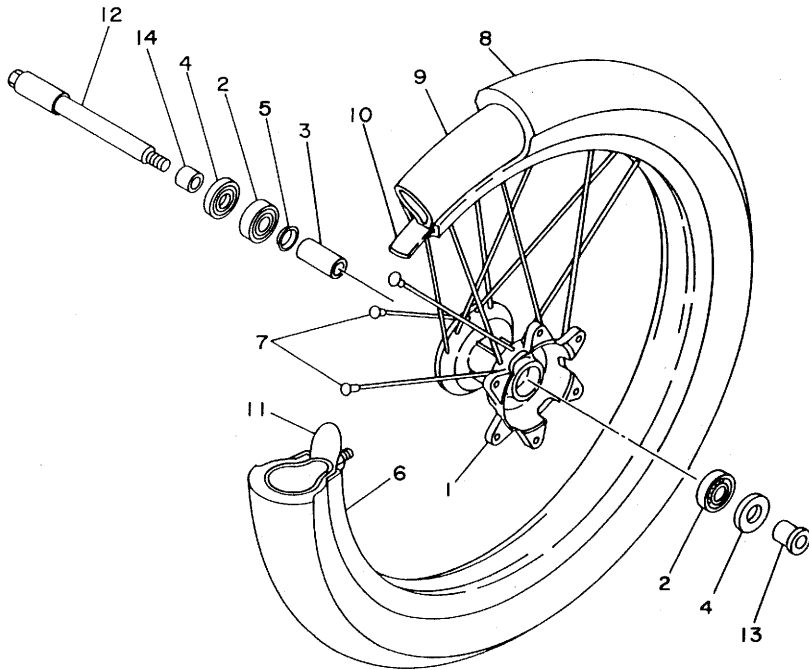

4EW1100-3250

D4

FIG. 26 FRONT BRAKE CALIPER

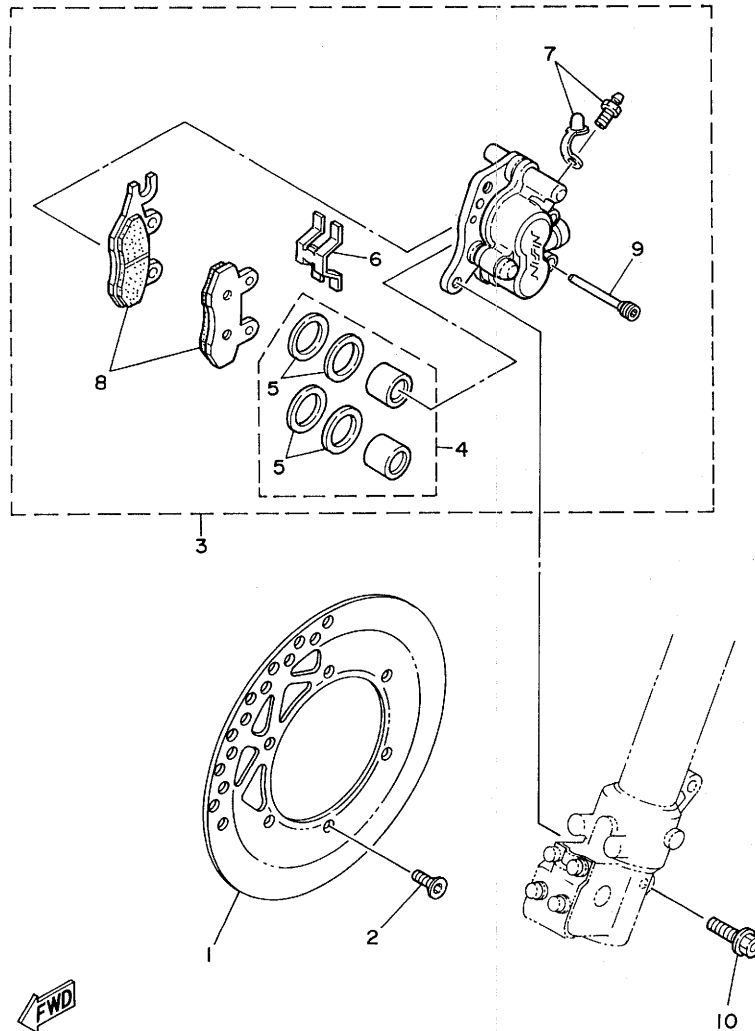

REF. NO.	PART NO.	DESCRIPTION	Q'TY	REMARKS
1	4JX-2582T-00	DISC, BRAKE	1	
2	90149-06272	SCREW	6	
3	4MX-2580T-00	CALIPER ASSY (LEFT)	1	
4	4EW-W0057-00	.PISTON ASSY, CALIPER	1	
5	3JD-W0047-00	..CALIPER SEAL KIT	1	
6	3SP-25919-01	.SUPPORT, PAD	1	
7	36Y-W0048-00	.BLEED SCREW KIT	1	
8	4MX-W0045-00	.BRAKE PAD KIT	1	
9	3GD-25933-00	.PIN, PAD	2	
10	90105-08659	BOLT, WASHER BASED	2	



4JY1100-4260

D5

FIG. 27 REAR WHEEL

REF. NO.	PART NO.	DESCRIPTION	Q'TY	REMARKS
1	4EW-25311-00	HUB, REAR	1	
2	4EW-25317-00	SPACER, BEARING	1	
3	93306-00418	BEARING	3	
4	93106-28023	OIL SEAL	2	
5	94418-19537	RIM (1.85-19)	1	
6	3JD-25304-00	SPOKE SET, REAR	1	
7	94110-1900X	TIRE (100/90-19 57M K695)	1	UR DUNLOP
	94110-1902X	TIRE (100/90-19 57M D752)	1	UR DUNLOP FOR EUROPE
8	94210-19224	TUBE (100/90-19 TR4 BTL)	1	DUNLOP
9	94327-19111	BAND, RIM (2.75-19)	1	INOUE
10	2X3-25394-00	SPACER, BEAD	1	
11	39W-25450-00	SPROCKET, DRIVEN (50T)	1	STD
	39W-25444-01	SPROCKET, DRIVEN (44T)	1	AP
	39W-25445-01	SPROCKET, DRIVEN (45T)	1	AP
	39W-25446-01	SPROCKET, DRIVEN (46T)	1	AP
	39W-25448-00	SPROCKET, DRIVEN (48T)	1	AP
	2HH-25449-00	SPROCKET, DRIVEN (49T)	1	AP
	3JD-25451-01	SPROCKET, DRIVEN (51T)	1	AP
	39W-25452-01	SPROCKET, DRIVEN (52T)	1	AP
12	90109-081G1	BOLT	6	
13	95617-08100	NUT, U	6	
14	90201-086P8	WASHER, PLATE	6	
15	90480-10068	GROMMET	1	
16	90387-2000B	COLLAR	1	
17	90387-2000C	COLLAR	1	
18	4JX-25388-00	PULLER, CHAIN 1	2	
19	90101-08699	BOLT	2	
20	95707-08500	NUT, FLANGE	2	

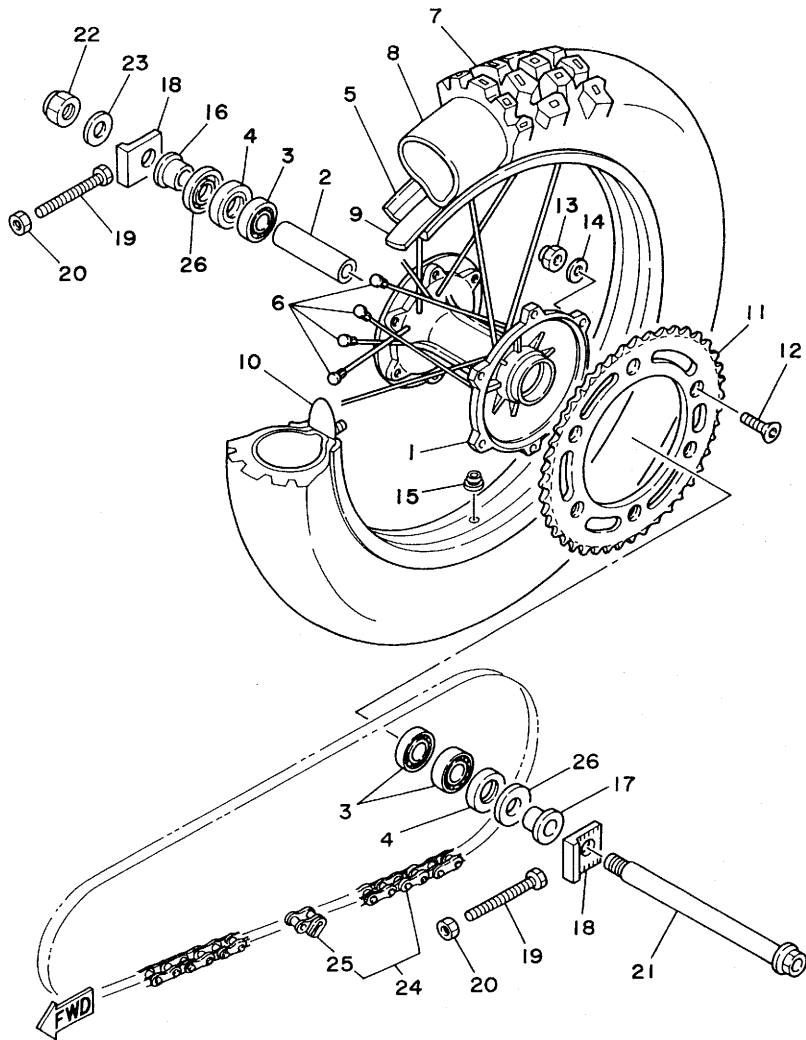

4EW1100-3270

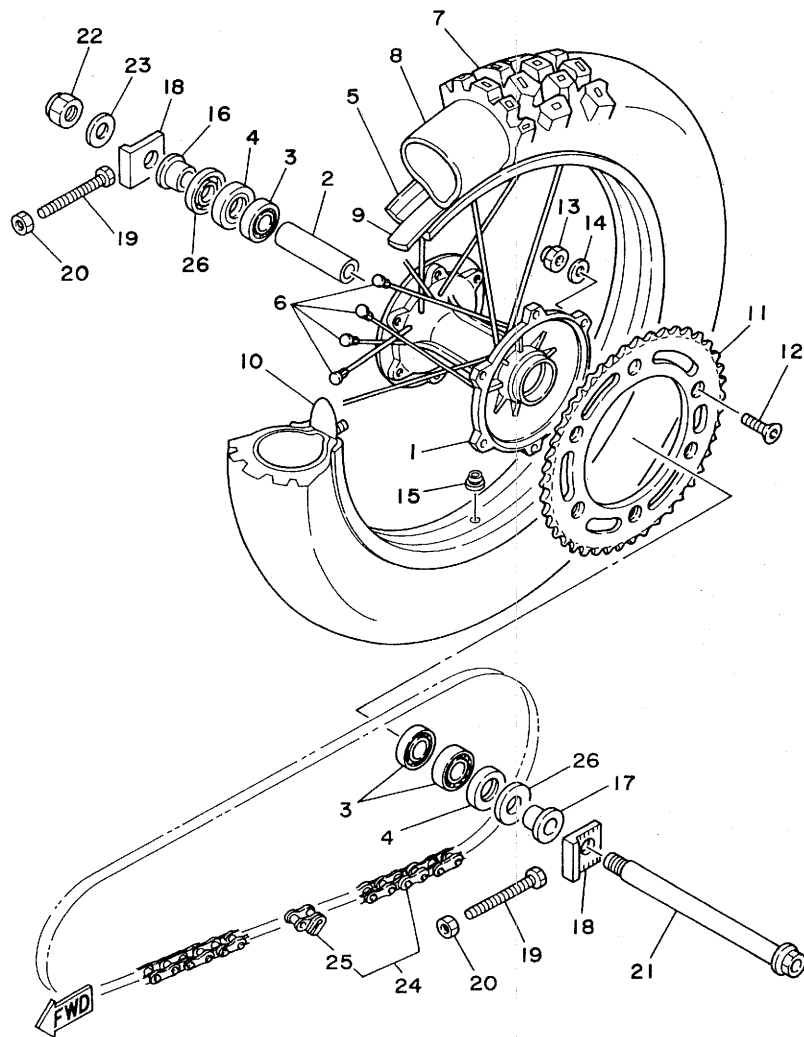

FIG. 27 REAR WHEEL

REF. NO.	PART NO.	DESCRIPTION	Q'TY	REMARKS
21	3JD-25381-01	AXLE, WHEEL	1	
22	90185-18104	NUT, SELF-LOCKING	1	
23	92907-18600	WASHER	1	
24	9Y581-44113	CHAIN (D.I.D.520DS-114LL)	1	
25	94681-44001	.JOINT, CHAIN	1	
26	4V4-25367-00	COVER, HUB DUST	2	

4EW1100-3270

D7

FIG. 28 REAR BRAKE CALIPER

REF. NO.	PART NO.	DESCRIPTION	Q'TY	REMARKS
1	4MX-2582W-00	DISC, REAR BRAKE 2	1	
2	90149-06272	SCREW	6	
3	4MX-2580W-00	CALIPER ASSY, REAR 2	1	
4	3SP-W0057-50	.PISTON ASSY, CALIPER	1	
5	3JD-W0047-50	..CALIPER SEAL KIT	1	
6	4GY-25919-50	.SUPPORT, PAD	1	
7	36Y-W0048-00	.BREED SCREW KIT	1	
8	4GY-W0046-00	.BRAKE PAD KIT 2	1	
9	3SP-25924-51	.PIN, PAD	2	
10	4GY-25827-50	.SHIM, CALIPER	1	
11	4GY-22898-50	.INSULATOR, HEAT	1	
12	4MX-25718-00	PROTECTOR, DISK BRAKE	1	
13	95027-06012	BOLT, FRANGE	2	
14	4GY-27491-00	PROTECTOR	1	
15	95027-06016	BOLT	2	

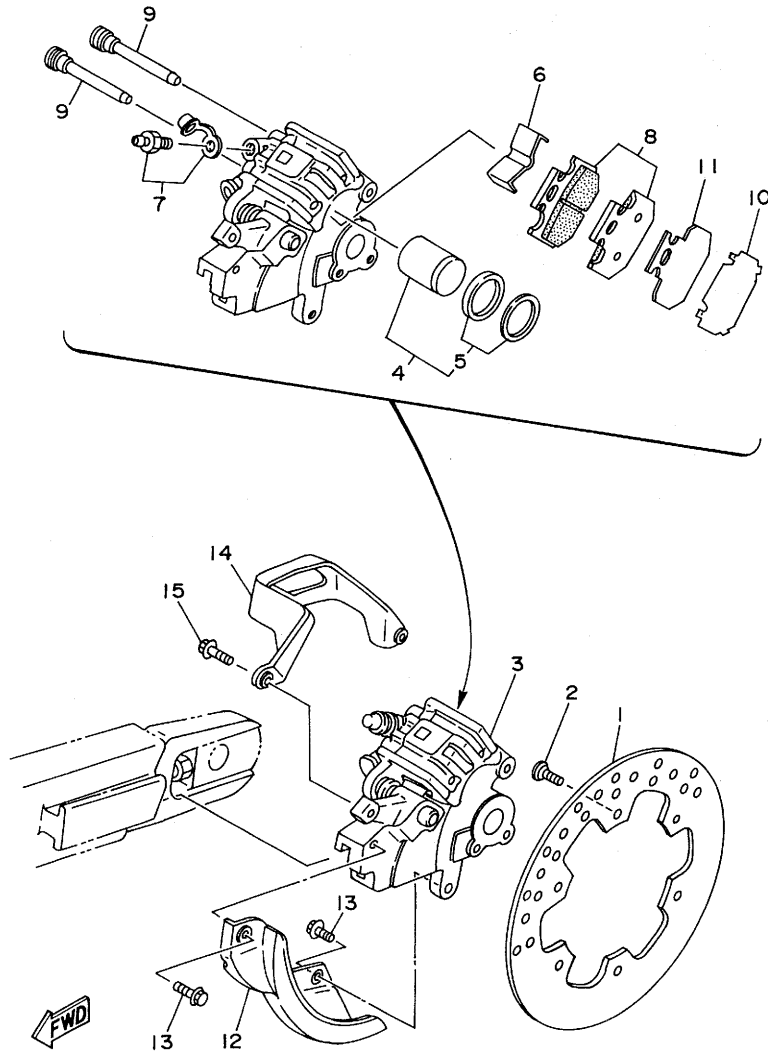

4PE1100-5280

D8

FIG. 29 STEERING HANDLE. CABLE

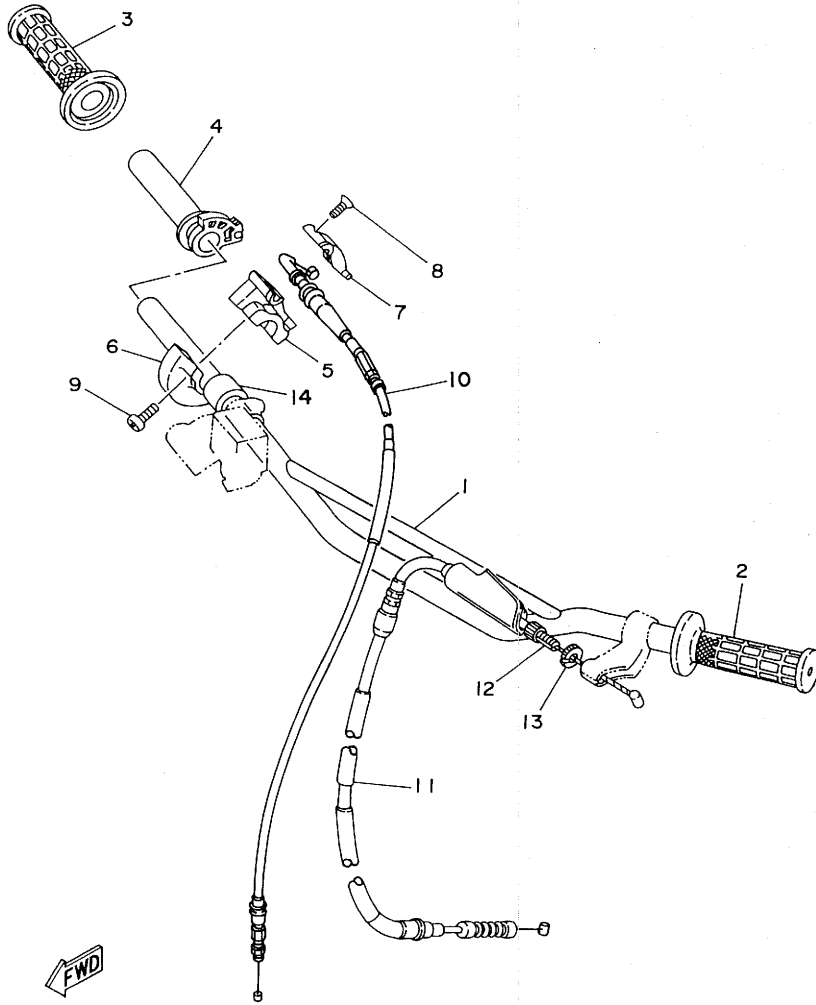

REF. NO.	PART NO.	DESCRIPTION	Q'TY	REMARKS
1	4JX-26111-00	HANDLEBAR	1	
2	1LX-26241-01	GRIP (LEFT)	1	
3	1LX-26242-01	GRIP (RIGHT)	1	
4	23X-26243-00	TUBE, THROTTLE GUIDE	1	
5	23X-26281-00	CAP, GRIP UPPER	1	
6	431-26282-02	CAP, GRIP LOWER	1	
7	5X2-2628H-01	CAP, WIRE	1	
8	98707-04012	SCREW, FLAT HEAD	2	
9	98507-05016	SCREW, PAN HEAD	2	
10	4MX-26311-00	CABLE, THROTTLE 1	1	
11	4JY-26335-00	CABLE, CLUTCH	1	
12	90123-08090	BOLT	1	
13	90179-08401	NUT	1	
14	90560-22281	SPACER	1	

4PE1100-5290

D9

FIG. 30 FRONT MASTER CYLINDER

REF. NO.	PART NO.	DESCRIPTION	Q'TY	REMARKS
1	4MX-25872-00	HOSE, BRAKE 1	1	
2	3LC-25885-00	JOINT	1	
3	3SP-25870-01	MASTER CYLINDER SUB ASSY	1	
4	3SP-W0041-00	.CYLINDER KIT, MASTER	1	
5	56A-25854-00	.DIAPHRAGM, RESERVOIR	1	
6	2VN-25852-01	.CAP, RESERVOIR	1	
7	98706-04012	.SCREW, FLAT HEAD	2	
8	56A-25867-00	BRACKET, MASTER CYLINDER	1	
9	90501-061G2	SPRING, COMPRESSION	1	
10	95027-06025	BOLT, FLANGE	2	
11	90201-10118	WASHER, PLATE	3	
12	90401-10034	BOLT, UNION	1	
13	56A-26372-01	COVER, HANDLE LEVER 1	1	

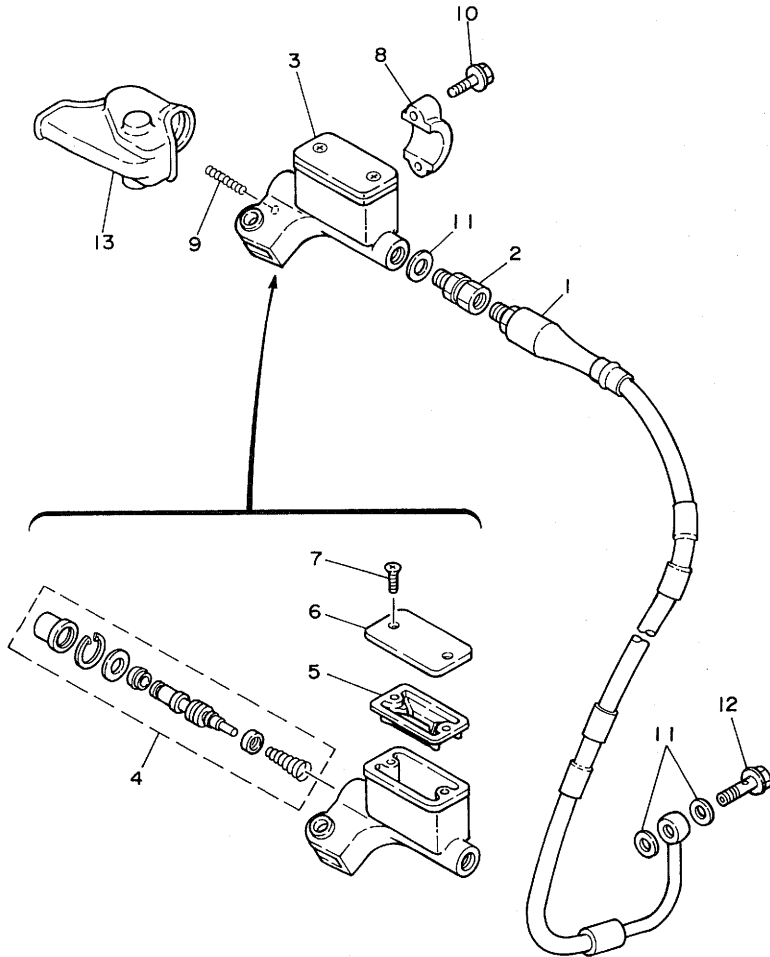

3SP1100-0300

D10

FIG. 31 STAND. FOOTREST

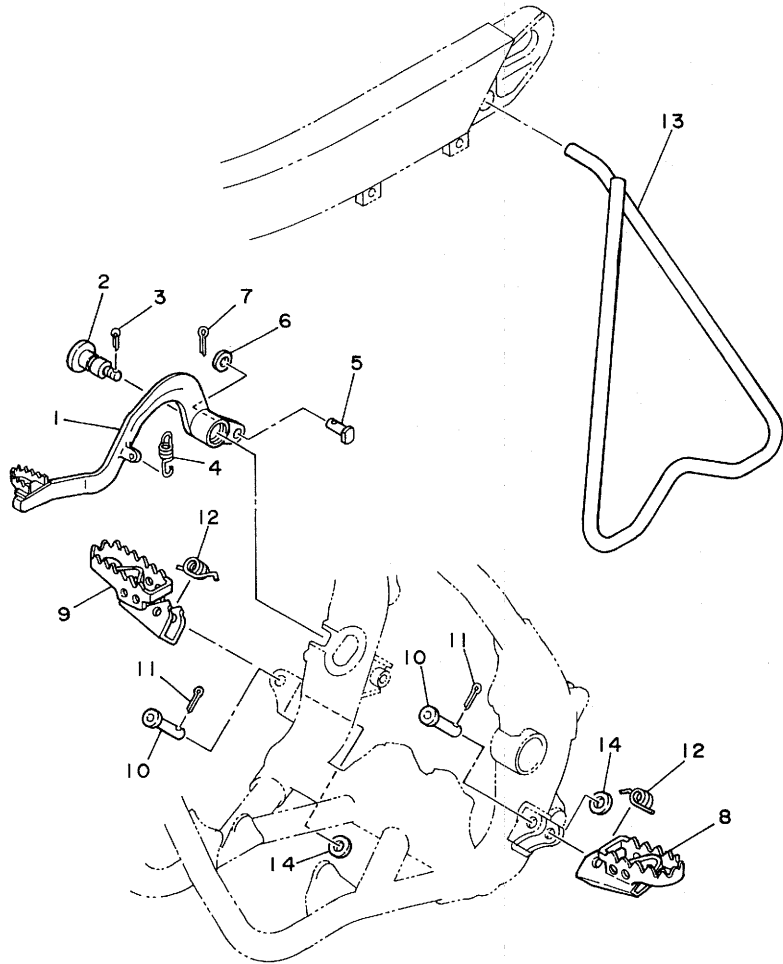

REF. NO.	PART NO.	DESCRIPTION	Q'TY	REMARKS
1	4JX-27200-00	PEDAL, BRAKE	1	
2	4MX-27217-00	BOLT	1	
3	91490-20020	PIN, COTTER	1	
4	90506-15480	SPRING, TENSION	1	
5	90240-08120	PIN, CLEVIS	1	
6	92901-08600	WASHER, PLATE	1	
7	91401-25020	PIN, COTTER	1	
8	4DA-27411-00	FOOTREST 1	1	
9	4DA-27421-00	FOOTREST 2	1	
10	90240-10117	PIN, CLEVIS	2	
11	91401-25020	PIN, COTTER	2	
12	90508-28777	SPRING, TORSION	2	
13	3SP-27311-00	STAND, SIDE	1	
14	90201-10119	WASHER, PLATE	2	



3XK1100-1310

D11

FIG. 32 REAR MASTER CYLINDER

REF. NO.	PART NO.	DESCRIPTION	Q'TY	REMARKS
1	3SP-2583V-00	RR. MASTER CYLINDER ASSY	1	
2	1FK-W0042-50	.CYLINDER KIT, MASTER	1	
3	93210-15620	.O-RING	1	
4	2VN-25866-00	.CIRCLIP	1	
5	2VN-2582A-50	.JOINT	1	
6	3SP-27222-00	.JOINT	1	
7	95333-08600	.NUT	2	
8	4EW-25894-00	TANK, RESERVOIR	1	
9	3XP-25852-50	CAP, RESERVOIR	1	
10	2VN-25854-00	DIAPHRAGM, RESERVOIR	1	
11	2VN-25855-00	BUSH, DIAPHRAGM	1	
12	90467-11044	CLIP	2	
13	90445-137H9	HOSE	1	
14	92013-06016	BOLT	2	
15	95027-06012	BOLT	1	
16	4JX-25873-00	HOSE, BRAKE 2	1	
17	90401-10034	BOLT, UNION	2	
18	90201-10118	WASHER, PLATE	4	
19	2VM-25876-00	HOLDER, BRAKE HOSE 2	1	
20	97780-50110	SCREW, TAPPING	2	
21	90465-12362	CLAMP	1	
22	95027-06008	BOLT	2	

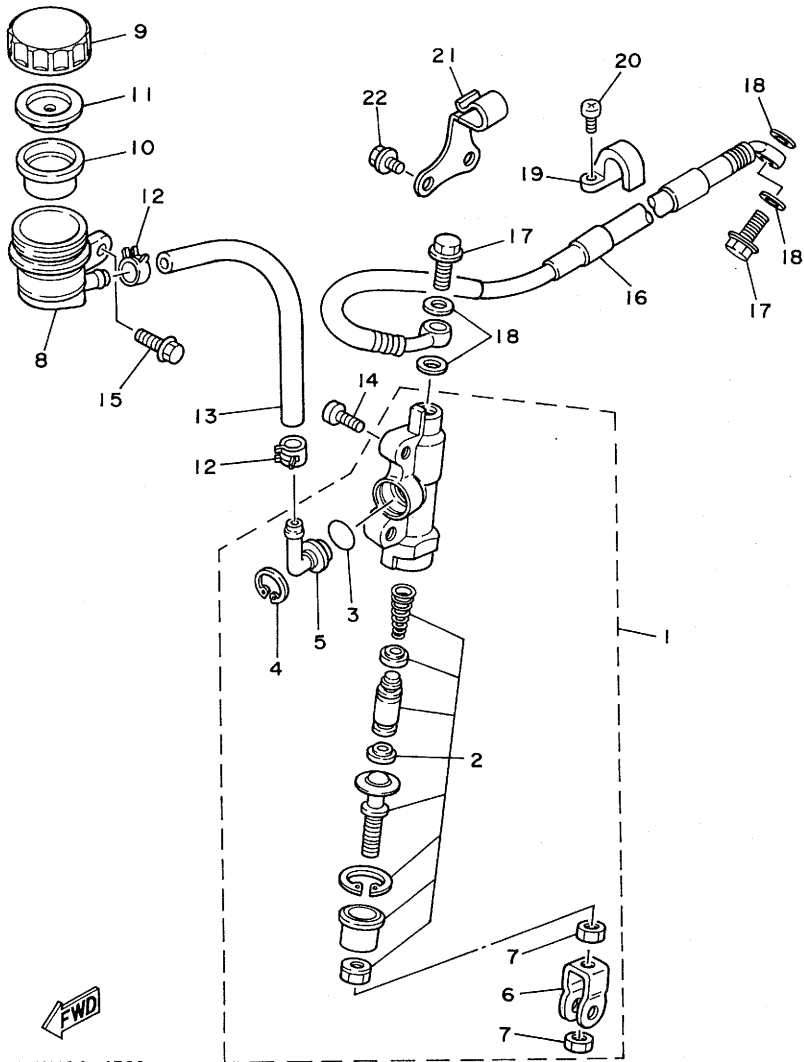

4JX1100-4320

D12

FIG. 33 GENERATOR

REF. NO.	PART NO.	DESCRIPTION	Q'TY	REMARKS
1	4JY-85510-00	STATOR ASSY	1	
2	4JY-85550-00	ROTOR ASSY	1	
3	90149-06011	SCREW	3	
4	95317-10600	NUT	1	
5	90201-10774	WASHER, PLATE	1	

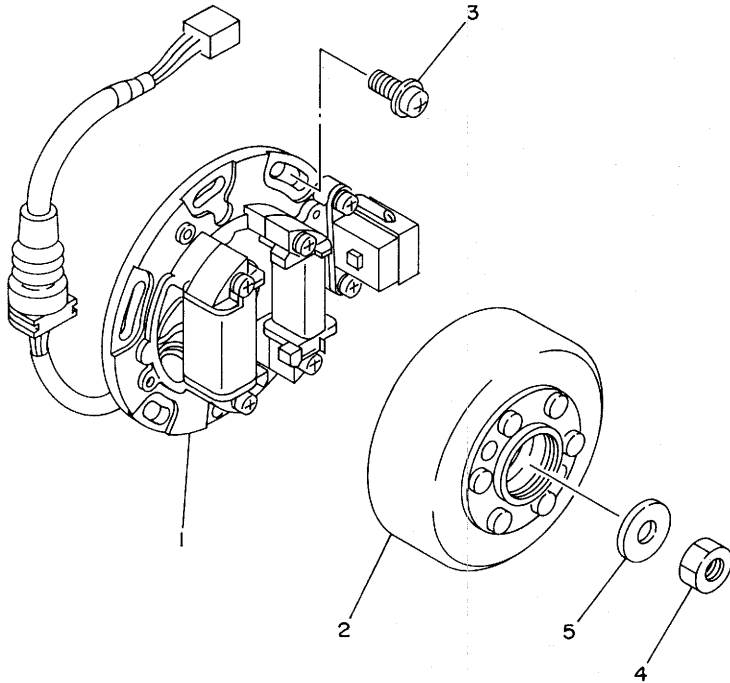

4JY1100-4330

D13

FIG. 34 HANDLE SWITCH. LEVER

REF. NO.	PART NO.	DESCRIPTION	Q'TY	REMARKS
1	38V-82911-00	HOLDER, LEVER 1	1	
2	38V-82913-00	HOLDER, LEVER LOWER 1	1	
3	4GY-83912-00	LEVER 1	1	
4	90109-06799	BOLT	1	
5	95607-06100	NUT, U	1	
6	97007-05016	BOLT	2	
7	3SP-83922-00	LEVER 2	1	
8	90109-06577	BOLT	1	
9	95607-06100	NUT, U	1	
10	90143-06024	SCREW, HEXAGON	1	
11	90170-06010	NUT	1	
12	23X-83976-00	SWITCH, HANDLE 1	1	
13	437-83936-01	BAND, SWITCH CORD	2	

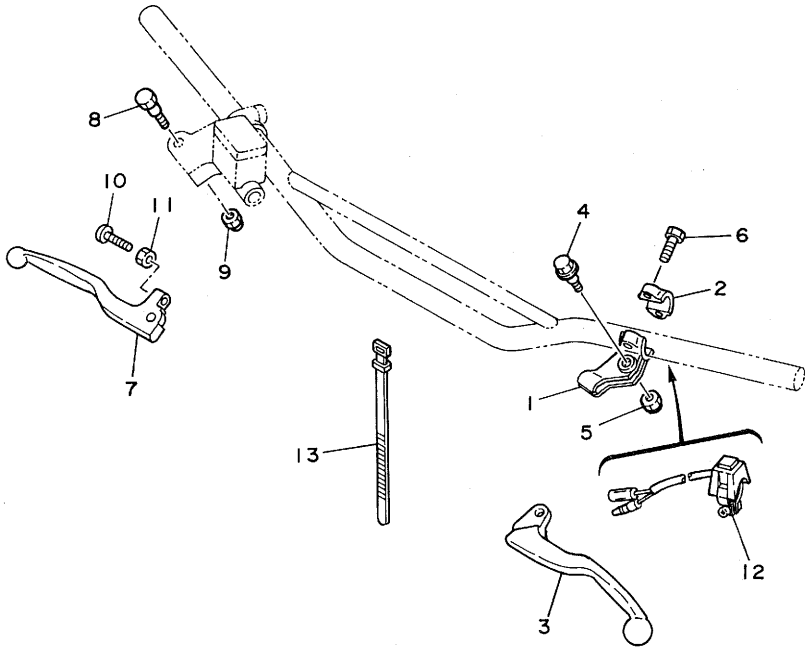

4JX1100-4340

D14

FIG. 35 ELECTRICAL 1

REF. NO.	PART NO.	DESCRIPTION	Q'TY	REMARKS
1	4PE-85540-00	C.D.I. UNIT ASSY	1	
2	4JY-82509-00	WIRE, SUB LEAD	1	
3	4JY-82310-00	IGNITION COIL ASSY	1	
4	91317-05016	BOLT	2	
5	4PE-82370-00	PLUG CAP ASSY	1	
6	4EX-85546-00	BAND	1	
7	25G-83936-01	BAND, SWITCH CORD	1	
8	12R-82591-00	BAND	1	
9	1UA-82591-00	BAND	1	
10	90464-14117	CLAMP	1	
11	437-83936-01	BAND, SWITCH CORD	1	

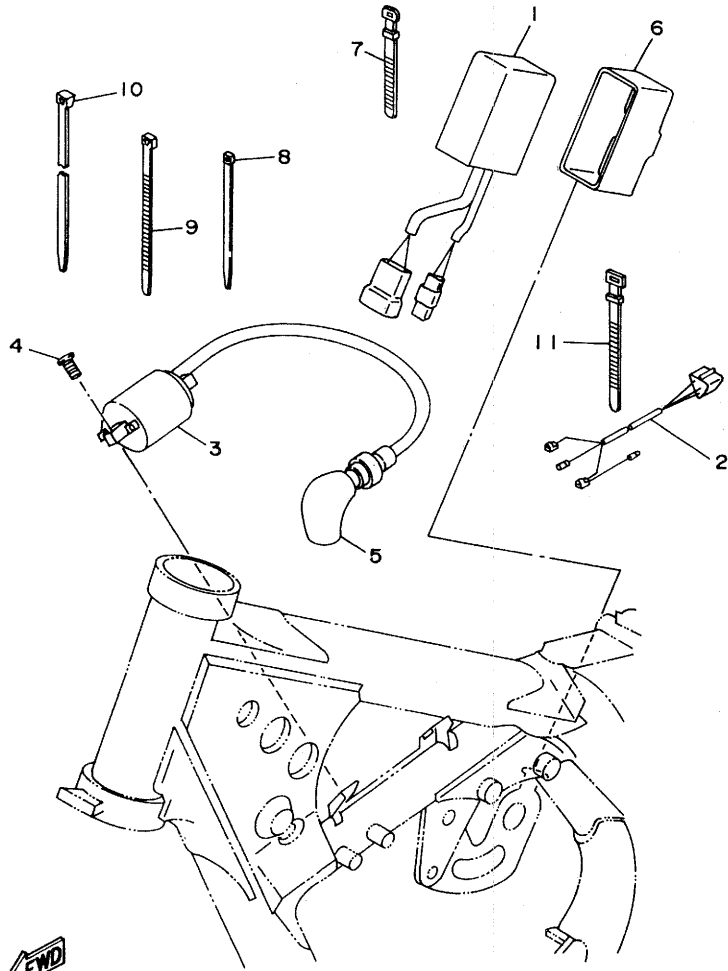

4PE1100-5350

D15

ALTERNATE PARTS

FIG. 36 ALTERNATE (CHASSIS)

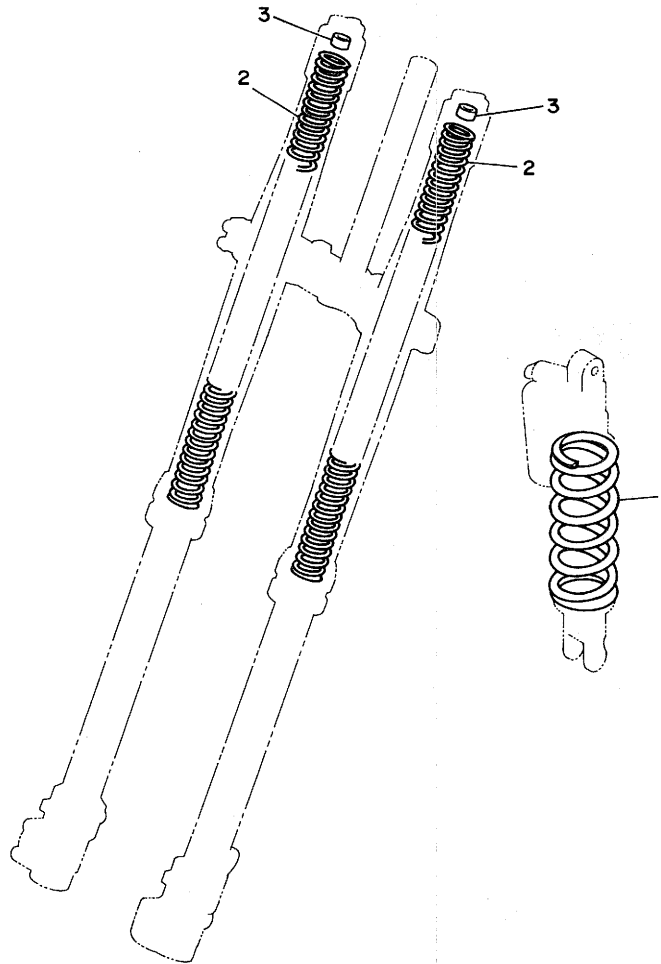

REF. NO.	PART NO.	DESCRIPTION	Q'TY	REMARKS
1	4JX-22212-10	SPRING (K=4.4)	1	AP
	4JX-22212-20	SPRING (K=4.6)	1	AP
	4JX-22212-30	SPRING (K=4.8)	1	AP
	4JX-22212-40	SPRING (K=5.0)	1	AP
	4JX-22212-50	SPRING (K=5.2)	1	AP
	4JX-22212-60	SPRING (K=5.4)	1	AP
2	3XJ-23141-10	SPRING, FRONT FORK (K=0.350)	2	AP
	3XJ-23141-L0	SPRING, FRONT FORK (K=0.365)	2	AP
	3XJ-23141-30	SPRING, FRONT FORK (K=0.380)	2	AP
	3XK-23141-L0	SPRING, FRONT FORK (K=0.390)	2	AP
	3XJ-23141-50	SPRING, FRONT FORK (K=0.400)	2	AP
	3XK-23141-M0	SPRING, FRONT FORK (K=0.410)	2	AP
	3XJ-23141-70	SPRING, FRONT FORK (K=0.420)	2	AP
	3XJ-23141-80	SPRING, FRONT FORK (K=0.430)	2	AP
3	3XJ-23364-L0	COLLAR 2	1	UN



3XJ1100-1360

E2

REPAIR KIT

FIG. 37 REPAIR KIT

REF. NO.	PART NO.	DESCRIPTION	Q'TY	REMARKS
1	4PE-11630-00	PISTON ASSY (STD)	1	
2	4JY-11631-00-B0	.PISTON (STD)	1	ORANGE
3	4JY-11611-00	.RING, PISTON	1	
4	4PE-11633-00	.PIN, PISTON	1	
5	93450-17129	.CIRCLIP	2	
6	4PE-11650-00	CONNECTING ROD ASSY	1	
7	4PE-11651-00	.ROD, CONNECTING	1	
8	3JD-11681-01	.PIN, CRANK 1	1	
9	90209-22257	.WASHER	2	
10	93310-522P7	.BEARING, CYLINDRICAL	1	
11	93310-216L2	.BEARING, CYLINDRICAL	1	

E3

INDEX

NUMERICAL INDEX

PART NO.	GRID NO.	PART NO.	GRID NO.	PART NO.	GRID NO.	PART NO.	GRID NO.	PART NO.	GRID NO.	PART NO.	GRID NO.
3SP-W0041-00	D-10	5X4-11952-00	B- 4	4KM-14142-45	B-10	4JY-15462-00	B-13	4JY-21190-00-P1	C- 6	4JX-22226-00	C-11
1FK-W0042-50	D-12	24X-11953-01	B- 4	4KM-14142-50	B- 9	4JY-15463-00	B-13	46X-21269-00	C-10	3SP-22234-00	C-11
4MX-W0045-00	D- 5	4JY-11990-00	B- 4	4KM-14142-55	B- 9	4DB-15620-03	B-14	4JY-21274-00	C- 6	3SP-22241-00	C-11
4GY-W0046-00	D- 8	4JY-11991-00	B- 3	4KM-14142-60	B-10	4DB-15621-03	B-14	4JY-21425-00	C- 6	3XJ-22253-00	C-11
3JD-W0047-00	D- 5	4JY-11993-00	B- 3	4KM-14142-65	B-10	1LX-15641-00	B-14	4DA-21511-00	C- 7	4EW-22253-00	C-11
3JD-W0047-50	D- 8	4JY-11995-00	B- 3	137-14143-66-A1	B-10	1LX-15651-00	B-14	4EW-21611-00	C- 7	43M-22274-00	C-11
36Y-W0048-00	D- 5	4EW-1240A-01	B- 7	137-14143-68	B-10	1LX-15660-02	B-14	39X-21642-00	C- 7	4JX-22355-01	C- 9
	D- 8	4JY-12422-00	B- 6	137-14143-70	B-10	3XJ-16111-00	B-15	4EW-21711-01	C- 8	4EW-22474-00	C-11
3SP-W0057-50	D- 8	4JY-12428-00	B- 6	137-14143-72	B-10	4JY-16150-00	B-15	4EW-2172A-00	C- 8	3JD-22475-00	C-11
4EW-W0057-00	D- 5	1LX-12450-00	B- 6	137-14143-74	B-10	3XJ-16164-00	B-15		C- 8	3JE-22475-00	C-11
4JY-11111-01	B- 2	1LX-12459-00	B- 6	137-14143-76	B-10	3XJ-16181-00	B-15	4EW-21721-01	C- 8	4GY-22898-50	D- 8
4PE-11165-00	B- 2	4EX-12461-00	B- 7	137-14143-78	B-10	3XJ-16321-00	B-15	4PE-2173E-00	C- 8	4PE-23102-L0	C-13
4JY-11166-00	B- 2	22W-12462-00	B- 7	4PE-14147-00	B-10	3XJ-16324-00	B-15	4PE-2173F-00	C- 8	4PE-23103-L0	C-13
4JY-1131A-01	B- 2	4EX-12469-00	B- 7	4PE-1416A-00	B-10	3JD-16340-00	B-15	4PE-2173G-00	C- 8	4EW-23110-L0	C-13
4JY-1131E-00	B- 2	4EX-12477-01	B- 7	3JE-14171-00	B- 9	4EX-16351-00	B-15	4EW-21731-00	C- 8	4EW-23111-L0	C-13
4JY-1131M-00	B- 3	4DC-1248A-00	B- 7	4PE-14185-00	B- 9	3SB-16356-00	B-15	4EW-21741-00	C- 8	4GY-22898-50	D- 8
4JY-1131V-01	B- 2	4EW-12482-01	B- 7	353-14186-00	B- 9	4EX-16371-00	B-15	3JD-21748-00	C- 7	3SP-23113-L0	C-13
4PE-11310-00	B- 2	3AK-12483-00	B- 7	4PE-14194-00	B- 9	4EX-16382-00	B-15	4PE-21783-00	C- 8		C-14
4JY-1132A-01	B- 2	4JY-12483-00	B- 7	2HH-14197-00	B- 9	3SR-17121-00	C- 2	4EW-22110-02	C- 9	3JD-2312G-L0	C-13
4JY-11351-00	B- 2	353-13115-01	B-12	3X3-14197-00	B- 9	4EX-17131-00	C- 2	156-22127-00	C- 9		C-14
4JY-11354-00	B- 3	4PE-13565-00	B- 8	4PE-14197-00	B-10	4EX-17151-00	C- 2	4MX-22128-00	C- 9	4EW-23120-L0	C-13
4PE-11400-00	B- 5	4PE-13610-00	B- 8	4PE-14243-00	B- 9	4EX-17161-00	C- 2	4EW-22129-00	C- 9	4EW-23125-L0	C-13
4JY-11412-00	B- 5	4PE-13613-00	B- 8	4PE-14261-00	B- 9	1LX-17211-01	C- 2	1LX-22141-00	C- 9		C-14
4JY-11422-00	B- 5	4JY-13616-00	B- 8	4PE-14411-00	B- 8	3XJ-17221-00	C- 2	4EW-22151-01	C- 9	2KF-23127-01	C-14
4JY-11611-00	B- 5	4PE-14101-00	B- 9	4PE-14451-00	B- 8	3SR-17231-00	C- 2	4EW-2217A-00	C- 9	4PE-2313B-00	C-15
	E- 3	4PE-14101-10	B- 9	4PE-14453-00	B- 8	4EX-17241-00	C- 2	4EW-2217F-00	C-10	4PE-2313C-00	C-15
4PE-11630-00	E- 3	4PE-14101-20	B- 9	3JD-14458-00	B- 8	4EX-17251-00	C- 2	3JD-22178-10	C- 6	4MX-23136-L0	C-13
4JY-11631-00-A0	B- 5	4PE-14103-00	B- 9	3JD-14459-00	B- 8	4EX-17261-00	C- 2	4EW-22178-00	C- 6		C-13
4JY-11631-00-B0	B- 5	3JD-14104-00	B- 9	3JD-14462-00	B- 8	3XJ-17411-00	C- 2	4EW-22199-01	C- 9	4MX-2314A-L0	C-13
	E- 3	4PE-14107-38	B- 9	3JD-14477-00	B- 8	137-17417-00-05	B-14	4MX-22201-00	C-11		C-14
4JY-11631-00-C0	B- 5	4PE-14112-35	B-10	3JE-14561-00	B- 9	3XJ-17421-00	C- 2	4MX-22201-10	C-11	4EW-2314E-L0	C-15
4JY-11631-00-DO	B- 5	4PE-14112-40	B-10	1FN-14565-00	B- 9	4JY-18101-00	C- 5	4MX-22201-30	C-11	4MX-2314F-L0	C-15
4PE-11633-00	B- 5	4PE-14112-45	B-10	4PE-14610-00	B-11	1LX-18110-02	C- 5	4PE-22201-20	C-11	4MX-2314G-L0	C-15
	E- 3	3XK-14115-00	B- 9	4JY-14615-00	B-11	3XJ-18122-00	C- 5	4PE-22210-00	C-11	4MX-2314H-L1	C-14
4PE-11650-00	E- 3	3JD-14116-H0	B- 9	4JY-1469A-01	B-11	4JY-18140-00	C- 4	4PE-22210-10	C-11	4MX-2314J-L0	C-14
4PE-11651-00	E- 5	3JD-14116-H1	B- 9	4JY-14753-01	B-11	4JY-18172-00	C- 5	4PE-22210-20	C-11	3XJ-23141-L0	E- 2
	E- 3	3JD-14116-H2	B- 9	565-14771-00	B-11	3XJ-18173-00	C- 5	4PE-22210-30	C-11	3XJ-23141-10	E- 2
3JD-11681-01	B- 5	3JD-14116-H3	B- 9	256-14919-00	B- 9	3XJ-18178-00	C- 5	4JW-22212-20	C-11	3XJ-23141-30	E- 2
	E- 3	3JD-14116-H4	B- 9	4JY-15111-00	B-12	3XJ-18182-00	C- 5	4JX-22212-20	E- 2	3XJ-23141-50	E- 2
4JY-11812-00	B- 2	4PE-14131-00	B- 9	4JY-15121-00	B-12	3XJ-18184-00	C- 5	4JX-22212-20	E- 2	3XJ-23141-70	E- 2
4JY-11832-01	B- 2	87M-14137-00	B-10	1RG-15363-00	B-13	4EW-18185-00	C- 5	4JX-22212-30	E- 2	3XJ-23141-80	E- 2
5X5-11911-01	B- 4	3TC-14141-R0	B-10	1LX-15383-00	C- 2	3JD-18511-01	C- 4	4JX-22212-40	E- 2	3XK-23141-L0	C-13
5X5-11912-01	B- 4	3TC-14141-R1	B-10	3XJ-15383-00	C- 2	2VN-18512-01	C- 4	4JX-22212-50	E- 2		C-14
4JY-11915-00	B- 4	3TC-14141-R2	B-10	4JY-15411-00	B-13	1LX-18513-01	C- 4	4JX-22212-60	E- 2		E- 2
5X4-11921-02	B- 4	3TC-14141-57	B-10	4JY-15415-00	B-13	4EX-18531-00	C- 4	3SP-22213-00	C-11	3XK-23141-M0	E- 2
3JE-11922-00	B- 4	3TC-14141-58	B-10	4EX-15421-00	B-13	4EX-18535-00	C- 4	3JD-22214-00	C-11	4JX-23142-L0	C-13
4JY-11931-01	B- 4	3TC-14141-59	B-10	4JY-15431-00	B-13	4JY-18540-00	C- 4	4MX-22216-00	C-11		C-14
4JY-11937-00	B- 4	4KM-14142-40	B-10	4JY-15451-00	B-13	4PE-21101-00-PO	C- 6	3JD-22224-00	C-11	3XJ-23143-L0	C-13

NUMERICAL INDEX

PART NO.	GRID NO.	PART NO.	GRID NO.	PART NO.	GRID NO.	PART NO.	GRID NO.	PART NO.	GRID NO.	PART NO.	GRID NO.
3XJ-23143-L0	C-14	4EW-24182-00	D- 2	4MX-25872-00	D-10	90105-05361	C-12	90183-06023	C- 7	90338-10132	C- 8
4DA-23144-L0	C-13	3JD-24186-00	D- 2	4JX-25873-00	D-12	90105-06452	C- 6	90183-06069	C- 8	90338-10150	C- 9
	C-14	3XJ-24380-00	D- 2	2VM-25876-00	D-12	90105-06553	B- 8	90185-14070	C-10	90340-12097	B-12
3XJ-23145-L0	C-13	3JD-24500-01	D- 2	3LC-25885-00	D-10	90105-08120	C- 6	90185-16127	C- 9	90380-16158	C- 9
	C-14	4X8-24512-00	D- 2	4EW-25894-00	D-12	90105-08659	D- 5	90185-18104	D- 7	90387-0600F	C- 8
4V4-23146-L0	C-13	3AJ-24534-00	D- 2	3SP-25919-01	D- 5	90105-10445	B-15	90201-057H5	B- 2		C- 8
	C-14	5X7-24611-01	D- 2	4GY-25919-50	D- 8	90105-10614	C-11		B- 4	90387-0603J	C- 8
3JD-23147-L0	C-13	5X7-24612-00	D- 2	3SP-25924-51	D- 8	90105-10733	C- 6	90201-063J2	B- 7		C- 8
	C-14	4EW-24728-00	D- 3	3GD-25933-00	D- 5	90106-08051	C- 6	90201-065F3	B-14	90387-063F7	C- 4
3SP-23153-L0	C-13	4MX-24731-00	D- 3	4JX-26111-00	D- 9	90109-06418	B-15	90201-06697	D- 2	90387-063G3	B-11
	C-14	4EW-24738-00	D- 3	1LX-26241-01	D- 9	90109-06577	D-14	90201-067J4	C- 6	90387-0700G	B- 7
4V4-23153-L0	C-13	4MX-24770-00	D- 3	1LX-26242-01	D- 9	90109-067F4	C- 8	90201-06765	B- 8	90387-0701A	C- 7
	C-14	4DA-25104-00	D- 4	23X-26243-00	D- 9		C- 8	90201-080E2	C- 6	90387-086N4	C- 6
3JD-23158-L0	C-13	4EW-25111-00	D- 4	5X2-2628H-01	D- 9	90109-06799	D-14	90201-08087	B- 2	90387-107R6	B-11
	C-14	146-25116-00	D- 4	23X-26281-00	D- 9	90109-08161	D- 6	90201-08326	C- 6	90387-152F2	B- 4
4PE-2316A-L0	C-13	4DA-25181-00	D- 4	431-26282-02	D- 9	90109-142F4	C- 9	90201-08512	B- 6	90387-160H4	B-12
	C-14	3JD-25304-00	D- 6	4MX-26311-00	D- 9	90109-147F2	C- 9	90201-086P8	C- 6	90387-164N2	C- 9
3SP-23166-L0	C-13	4EW-25311-00	D- 6	4JY-26335-00	D- 9	90110-05201	C- 9		D- 6	90387-164N3	C- 9
	C-14	4EW-25317-00	D- 6	56A-26372-01	D-10	90116-08318	B- 2	90201-08730	C- 6	90387-167Y9	C- 9
4EW-23167-L0	C-14	4V4-25367-00	D- 7	4JX-27200-00	D-11	90116-08388	B- 2	90201-08784	B- 6	90387-172Y9	D- 4
4MX-23170-L0	C-13	3JD-25381-01	D- 7	4MX-27217-00	D-11	90116-08394	B- 2	90201-101J1	C- 6	90387-173Y0	D- 4
	C-14	4JX-25388-00	D- 6	3SP-27222-00	D-12	90119-06063	C- 7	90201-10118	D-10	90387-2000B	D- 6
3XJ-23171-L0	C-13	2X3-25394-00	D- 6	3SP-27311-00	D-11	90119-06185	B-11		D-12	90387-2000C	D- 6
	C-14	5X2-25394-00	D- 4	4DA-27411-00	D-11		C- 7	90201-10119	B-15	90387-202A0	C- 3
3Y6-23183-00	C-11	39W-25444-01	D- 6	4DA-27421-00	D-11		C- 7		D-11	90387-202T9	B-15
24M-23184-00	C-11	39W-25445-01	D- 6	4GY-27491-00	D- 8		C-12	90201-10774	D-13	90401-10034	D-10
4EW-2331E-L0	C-15	39W-25446-01	D- 6	56A-28166-00	C- 6	90119-06225	C- 8	90201-14740	C-10		D-12
4PE-23340-L0	C-14	39W-25448-00	D- 6	4JY-82310-00	D-15		C- 8	90201-154E9	B- 4	90430-06014	B-13
4DA-23346-L0	C-15	2HH-25449-00	D- 6	4PE-82370-00	D-15	90122-06035	B- 8	90201-15701	C- 2		B-15
3SP-23356-L0	C-15	39W-25450-00	D- 6	4JY-82509-00	D-15	90123-08090	D- 9	90201-164H4	C- 9	90430-06166	B- 6
3SP-23357-L0	C-13	3JD-25451-01	D- 6	1UA-82591-00	D-15	90143-06024	D-14		C-10	90430-12207	B-12
	C-14	39W-25452-01	D- 6	12R-82591-00	C- 6	90149-06011	D- 2	90201-171G4	B-14	90445-08605	B-12
4JX-23363-L0	C-13	4MX-25718-00	D- 8		D-15		D-13	90201-204K8	B-15	90445-09058	D- 2
	C-14	4MX-2580T-00	D- 5	38V-82911-00	D-14	90149-06272	D- 5	90201-206K8	C- 2	90445-09100	D- 2
3XJ-23364-L0	E- 2	4MX-2580W-00	D- 8	38V-82913-00	D-14		D- 8	90201-22555	C- 2	90445-111J0	D- 2
4DA-23389-00	C-12	2VN-2582A-50	D-12	4GY-83912-00	D-14	90151-04048	C- 9	90201-247L2	C-12	90445-137H9	D-12
3SP-23393-L0	C-13	4JX-2582T-00	D- 5	3SP-83922-00	D-14	90152-06010	B-14	90201-286K9	C-12	90450-15041	B- 7
	C-14	4MX-2582W-00	D- 8	25G-83936-01	D-15	90159-06016	B-15	90202-05187	D- 2	90450-17036	B- 7
4EW-23416-00	C-12	4GY-25827-50	D- 8	437-83936-01	D-14	90159-06078	C- 4	90209-06096	B- 8	90450-22052	B- 7
4JX-23435-00	C-12	3SP-2583V-00	D-12		D-15	90170-06010	D-14	90209-18135	C- 2	90450-28014	B- 7
3SP-23441-00	C-12	2VN-25852-01	D-10	23X-83976-00	D-14	90170-16326	B-15	90209-18208	C- 2	90450-51070	B- 8
4DA-23485-01	C-12	3XP-25852-50	D-12	4JY-85510-00	D-13	90170-24373	C-12	90209-22257	B- 5	90450-70072	B- 8
4EW-24110-00	D- 2	2VN-25854-00	D-12	4PE-85540-00	D-15	90176-08026	B- 2		E- 3	90464-12224	B- 2
4EW-2412F-00	D- 2	56A-25854-00	D-10	4EX-85546-00	D-15	90179-06568	C- 9	90215-16245	B-15	90464-14117	D- 2
24X-24144-00	D- 2	2VN-25855-00	D-12	4JY-85550-00	D-13	90179-08401	D- 9	90215-20261	C- 3		D-15
3SP-24173-00	D- 2	2VN-25866-00	D-12	9Y581-44113	D- 7	90179-08491	B- 2	90240-08120	D-11	90465-08336	B-12
22W-24181-00	C- 8	56A-25867-00	D-10	90101-06664	C- 5	90179-16226	C- 3	90240-10117	D-11	90465-12362	D-12
4EW-24181-00	D- 2	3SP-25870-01	D-10	90101-08699	D- 6	90179-28650	C-12	90280-03017	B- 5	90467-09006	B- 7

NUMERICAL INDEX

PART NO.	GRID NO.	PART NO.	GRID NO.	PART NO.	GRID NO.	PART NO.	GRID NO.	PART NO.	GRID NO.	PART NO.	GRID NO.
90467-10008	D- 2	93102-22363	B- 5	93521-64032	B- 4	95027-06065	B- 6				
90467-11044	B- 2	93102-26042	C- 2	93603-14179	B- 4	95027-08035	C-12				
	D-12	93103-10168	B- 6	93603-22028	B- 6	95027-08040	C- 6				
90468-26048	B-14	93103-32099	B- 5	93604-10011	B- 6						
90480-10068	D- 6	93104-08040	B- 3		B-13	95027-08065	C- 6				
90480-10289	B-11		B- 4	9383A-12017	C- 3	95317-08700	C- 6				
90480-15528	B- 7	93106-22019	C- 9	9383A-13031	C- 3	95317-10600	D-13				
90480-16561	B-11	93106-22032	D- 4	9383A-14054	C- 3	95333-08600	D-12				
90480-18549	D- 2	93106-28023	D- 6	94108-2102V	D- 4	95607-05100	B- 8				
90501-05265	C- 5	93109-12012	C- 5	94108-217X2	D- 4	95607-06100	D-14				
90501-06162	D-10	93109-20029	C- 9	94110-1900X	D- 6						
90501-066J1	B- 2		C-10	94110-1902X	D- 6	95617-08100	C- 6				
90501-12081	B-14	93210-15171	B-14	94210-19224	D- 6						
90501-23598	B-15	93210-15620	D-12	94227-21123	D- 4	95617-08200	C- 6				
90501-264J6	B- 4	93210-19123	B-13	94307-21145	D- 4	95617-10100	C- 6				
90506-15480	D-11	93210-42728	B-11	94327-19111	D- 6	95617-10200	C-11				
90507-20052	B-11	93210-63442	B- 2	94416-21509	D- 4	95707-08500	D- 6				
90508-14783	B- 4	93210-90785	B- 2	94418-19537	D- 6	95817-08050	C- 6				
90508-26450	B-14	93300-60804	C- 6	94681-44001	D- 7	95817-08090	C- 6				
90508-26691	C- 4	93300-60814	B- 4	94702-00325	B- 2	97007-05016	B- 3				
90508-28777	D-11	93306-00316	D- 4	94703-00325	B- 2						
90508-295A7	C- 5	93306-00418	D- 6	95023-08040	C-14						
90560-08213	B- 4	93306-20469	C- 2	95027-06008	D-12	97027-06012	B-14				
90560-12280	C- 5	93306-30411	C- 2	95027-06010	C- 2	97027-06025	C- 5				
90560-17279	B-14	93306-37204	B- 5		B-13	97780-50110	D-12				
90560-17379	D- 4	93310-216L2	B- 5		C- 9	98503-03008	D- 2				
90560-22281	D- 9		E- 3	95027-06012	B-11	98507-03008	B- 8				
91A20-05065	B- 7	93310-225N0	B-15		C- 8	98507-04008	B- 9				
91317-04006	B- 4	93310-522P7	B- 5		C- 8	98507-04012	B- 9				
91317-04008	B- 2		E- 3		D- 8	98507-05014	B- 4				
91317-05016	D-15	93311-31567	C- 3		D-12	98507-05016	D- 9				
91317-06045	B-12	93311-41530	C- 2	95027-06014	C- 8	98507-06016	B-13				
91317-06055	B-12	93315-11206	B-15		C- 8	98507-06030	B-13				
91317-06070	B-12	93315-22046	C- 9	95027-06016	B-11	98511-04020	C-15				
91401-25020	D-11		C-10		C- 7	98706-04012	D-10				
	D-11	93317-22262	C- 9		D- 2	98707-04012	D- 9				
91490-20020	D-11	93332-00068	C-12		D- 3	98707-06012	C- 2				
92013-06016	D-12	93332-00078	C-12		D- 8		C- 2				
92017-06010	B-11	93340-21505	B- 4	95027-06020	B- 8	98707-06025	D- 2				
92901-08600	D-11	93342-21013	B-15	95027-06025	B-11	98907-05010	B- 2				
92907-05100	B- 4	93342-22215	C- 9		B-13	98907-05014	B- 3				
	B- 4	93410-22039	C- 2		D-10	98907-06020	D- 2				
92907-05600	B- 3		C- 2	95027-06030	B- 6	99009-10400	B-15				
92907-06600	B-13	93440-15012	B-14		B- 7	99080-07600	B- 6				
92907-18600	D- 7		C- 2		B-13	99510-10114	B- 2				
92990-03100	B- 8	93450-17129	B- 5	95027-06035	D- 2	99510-12016	B-12				
93102-12224	B-15		E- 3	95027-06040	B-13	99530-10014	B-13				
93102-17263	B-14	93507-32031	B-14	95027-06045	C- 9						